



DRIVING HUMAN AUDIO EXPERIENCE



DRIVING HUMAN AUDIO EXPERIENCE

CREATORS OF THE WORLD'S FINEST AUDIO TECHNOLOGY.

Corporate Presentation

1H 2023 Roadshow

05-10-2023

POWERSOFT AT THE GLANCE

Powersoft is a global leader in **audio amplification technologies**, advanced signal processing, and **unique transducer systems** for the pro-audio sector.

Powersoft specializes in the **design, production, and marketing of unique products** for customers and players of the professional audio market.

** 4 production plants are in outsourcing*

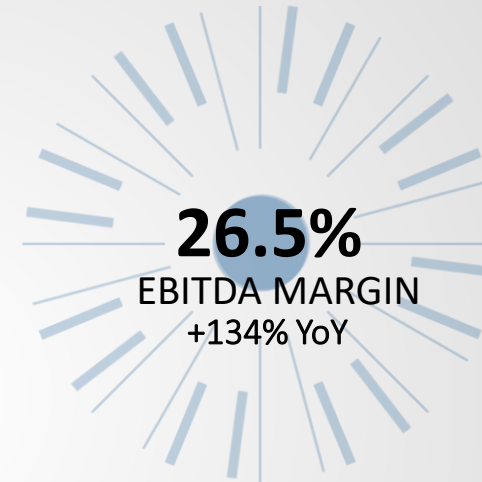

A HISTORY OF CONSISTENT GROWTH

Specialized in design, production and marketing of high-end **patented technologies** for professional audio applications.

Pioneers in switch-mode technology, **worldwide credited** as a standard setter and industry innovator.

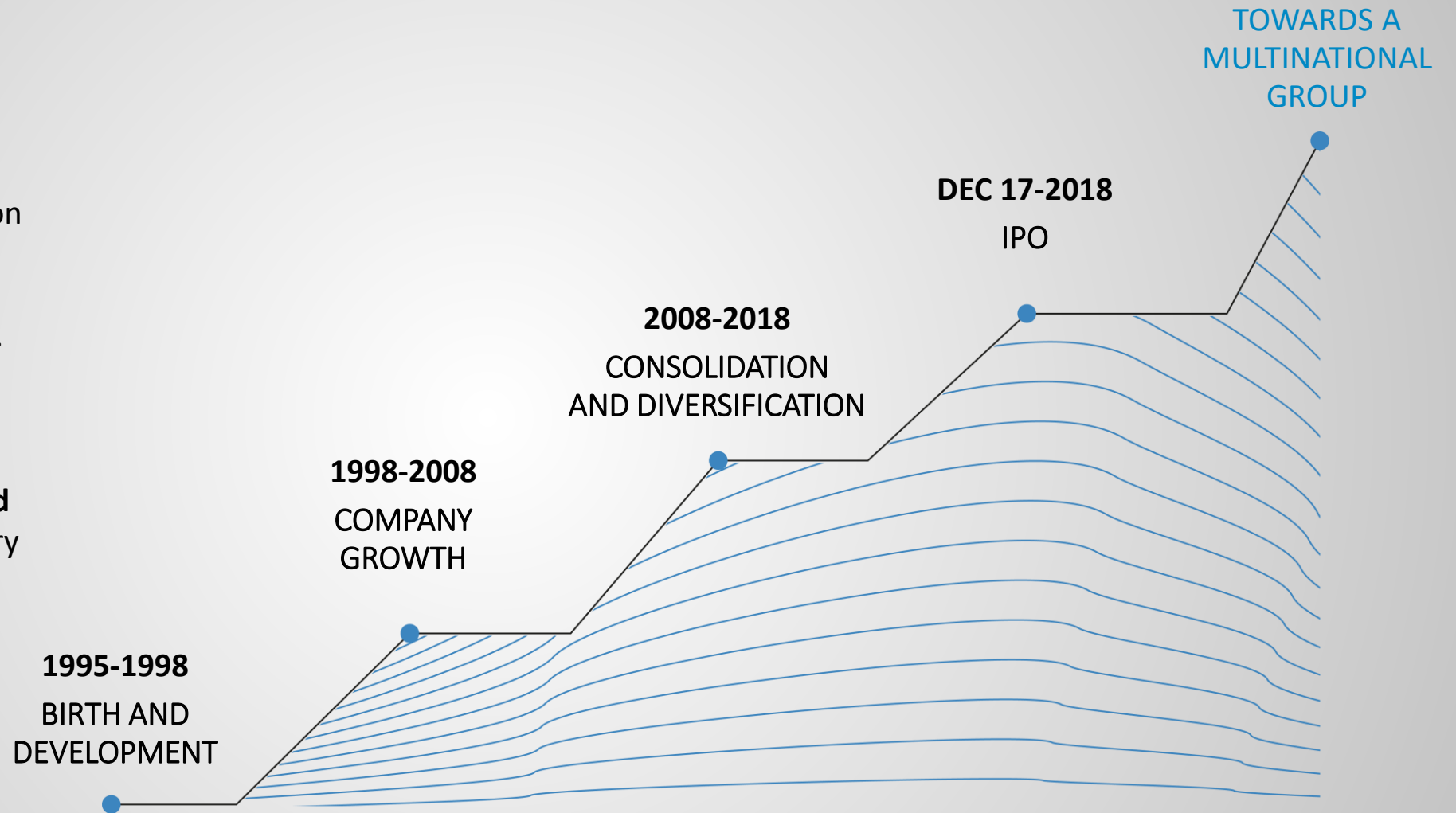

THE ITALIAN EXCELLENCE AT THE TOP OF HIGH-END PROFESSIONAL AUDIO MARKET

AT THE TOP OF THE PYRAMID

- Pioneers in the **high-end professional audio market**.
- Globally recognized **market setter of cutting-edge products**.
- Serving a diversified range of clients, both **professional customers** and **manufacturers**.
- **28 years as a forefront player in the market**, set to face future challenges and to exploit new opportunities.

PRO AUDIO
Loudspeaker, Amplifiers, Mixer,
DSP Transducer & others



MID MARKER (SEMI-PRO)
Portable sound, Headset,
microphones,
Mixer Console & others

MASS MARKET (CONSUMER)
TV Speaker System, Headset, inear
audio set & others

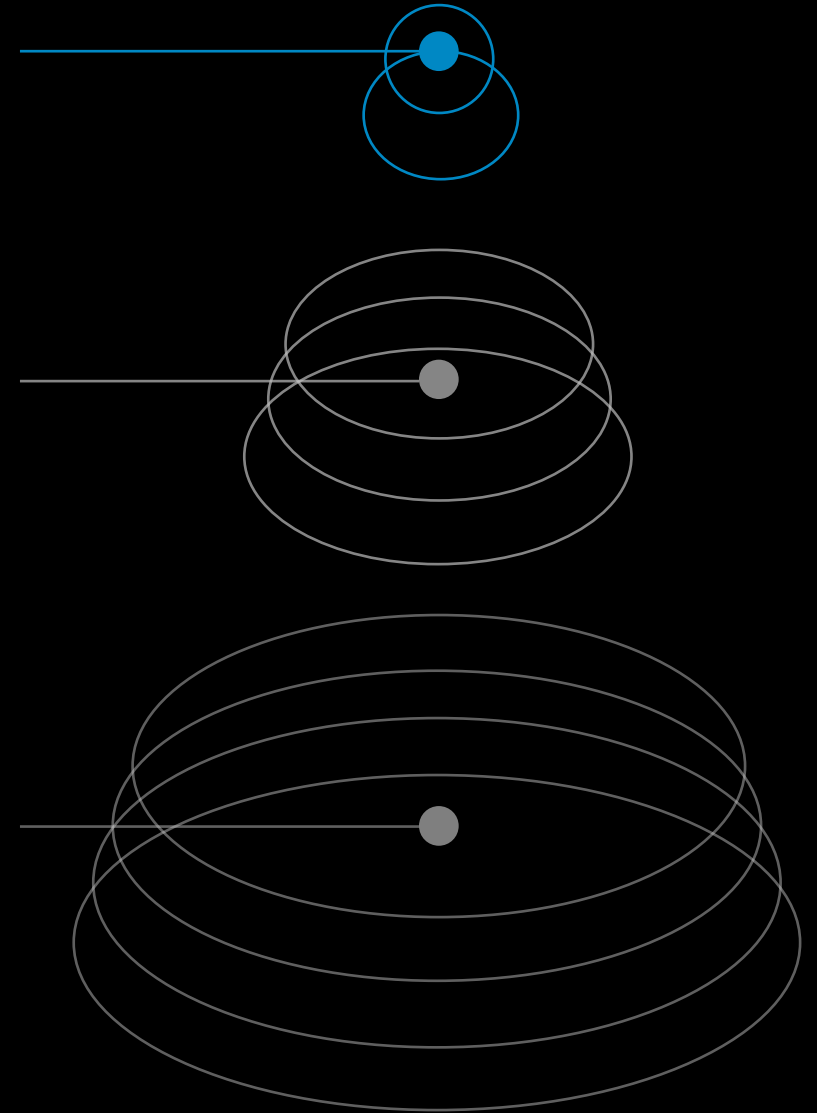

REDEFINING THE PRO AUDIO INDUSTRY BY SETTING NEW BENCHMARKS SINCE THE BEGINNING

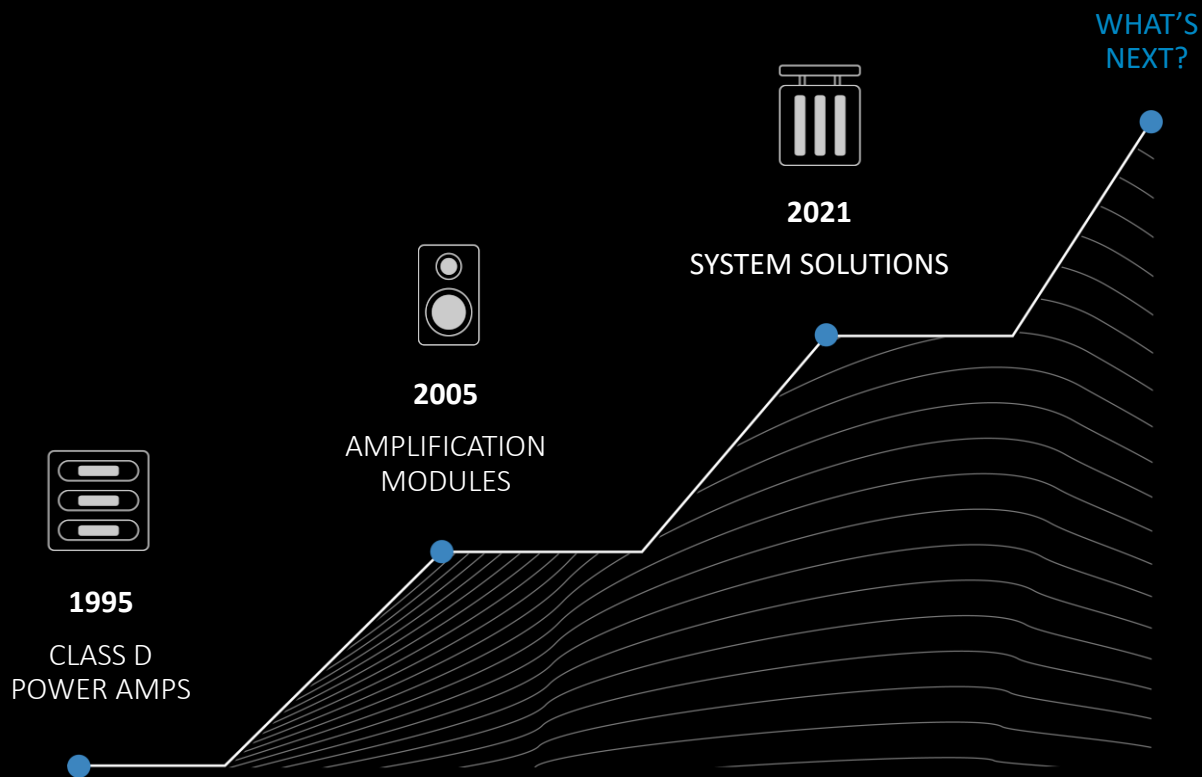

1H 2023 ROADSHOW

IMMERSIVE SOUND



44

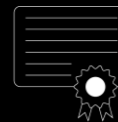

INTERNATIONAL PATENTS

40

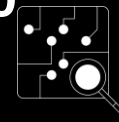

R&D PERSONNEL
(31% OF EMPLOYEES)

3.1M



~ 7% OF REVENUES
INVESTED IN R&D
IN FY 2022



Powersoft's own growth accelerator to support new projects and innovative technologies.



IT SOUNDS LIKE A WELL RECOGNIZED AUDIO TRACK

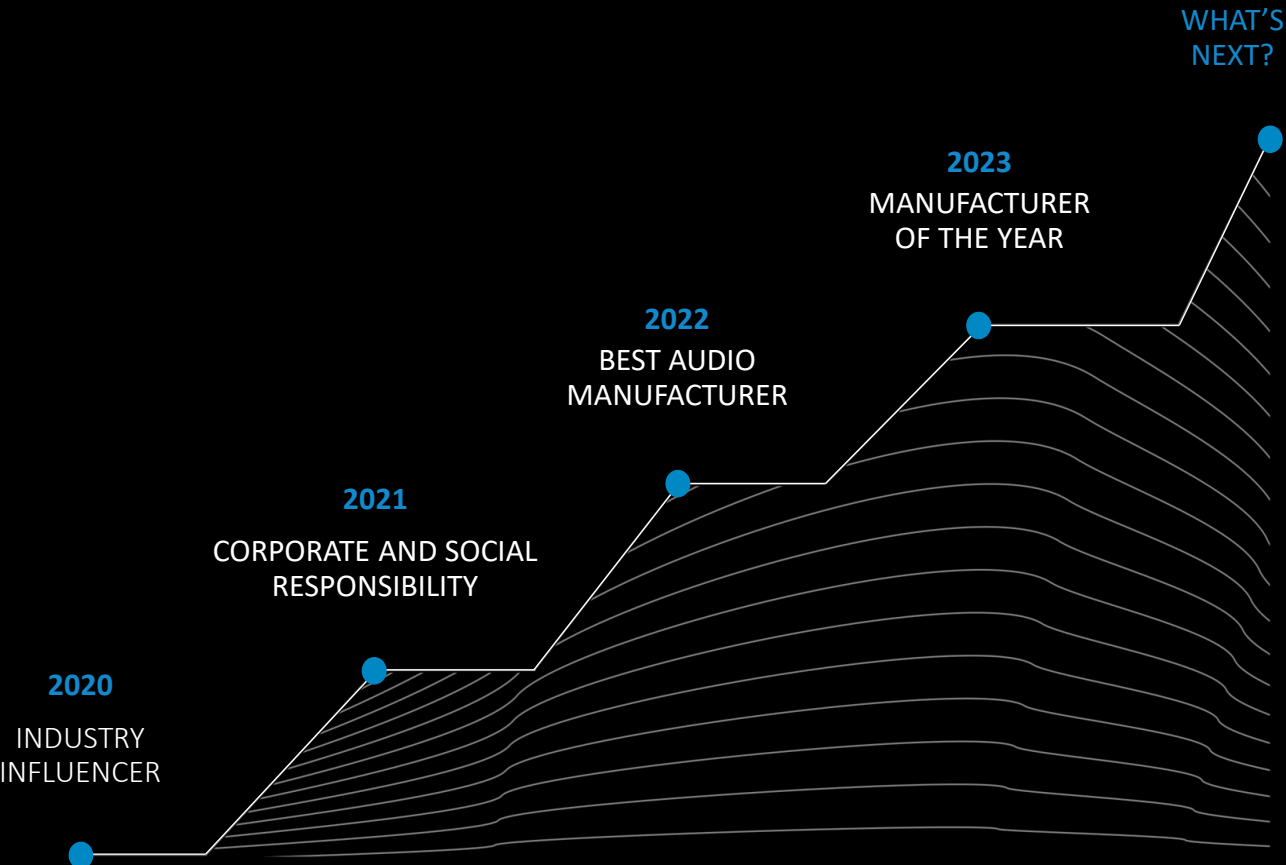

WHAT'S NEXT?



17



PRODUCT AWARDS

4



CORPORATE RECOGNITION



Powersoft's Trademark to identify environmentally friendly products



EFFICIENCY IS OUR SUSTAINABILITY PLEDGE

2.6 GWatt

Total nominal power sold

4.1 TWatt*h

Total used energy

9.7 TWatt*h

Total saved energy

850,000

Amplifiers sold



**POWERSOFT
AMPLIFIER**

7 Million

Tons of saved CO2



With **850,000 units** in the world, amounting to a total of **2.6 GW**, and assuming a conservative ten years of use, we estimate a total of **4.1 TWh of amplified sounds**, a **9.7 TWh saving in power losses**, which equates to **7 million tons of CO2** not being expelled into the atmosphere.



THE AMPLIFIER IS NOT A SPEAKER, WHICH IS NOT A LOUDSPEAKER. LET'S CLARIFY.

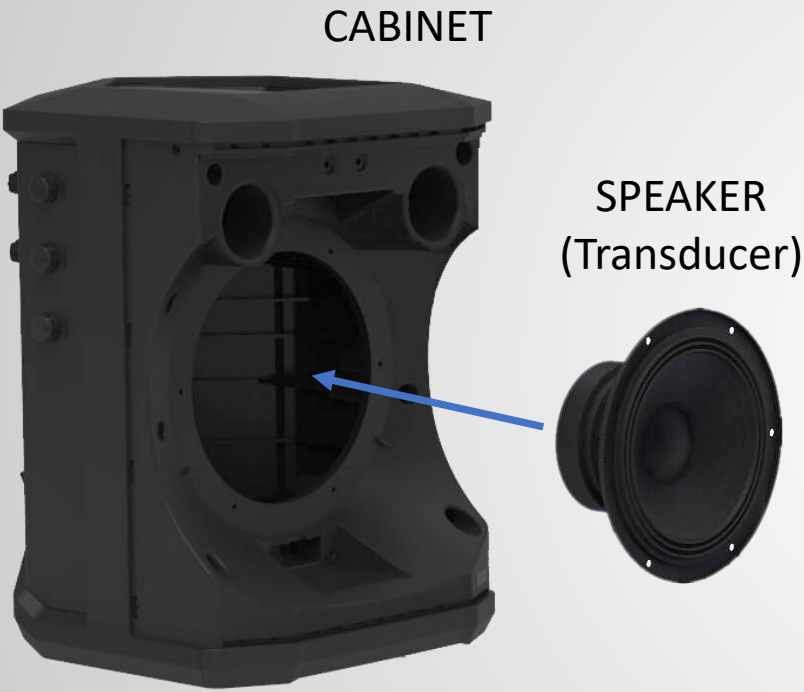

PASSIVE LOUDSPEAKER

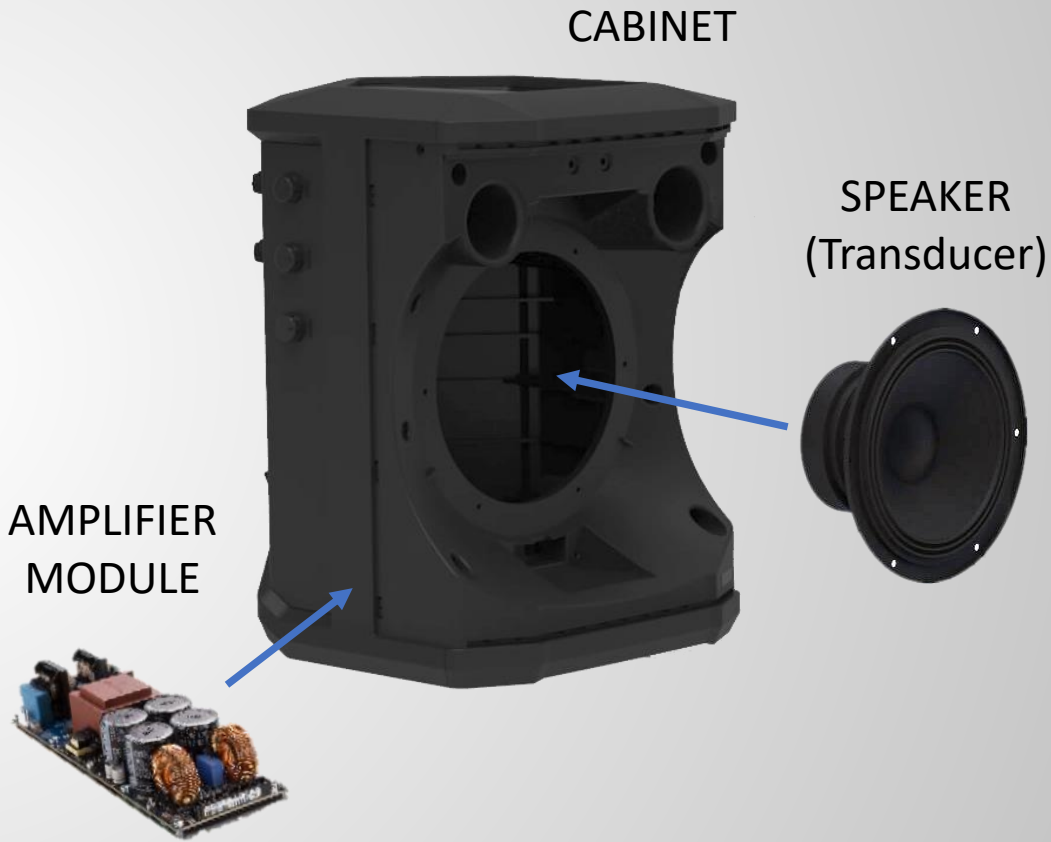

ACTIVE LOUDSPEAKER



THE AMPLIFIER IS NOT A SPEAKER WHICH IS NOT A LOUDSPEAKER. LET'S CLARIFY.

LOUDSPEAKER

SOURCES



AMPLIFIED
AUDIO SIGNAL

AUDIO SIGNAL



POWERSOFT AMPLIFIER PLATFORM

SYSTEM WITH A
PASSIVE LOUDSPEAKER

LOUDSPEAKER

SOURCES



AUDIO SIGNAL



POWERSOFT
AMPLIFIER
MODULE

SYSTEM WITH A
ACTIVE LOUDSPEAKER



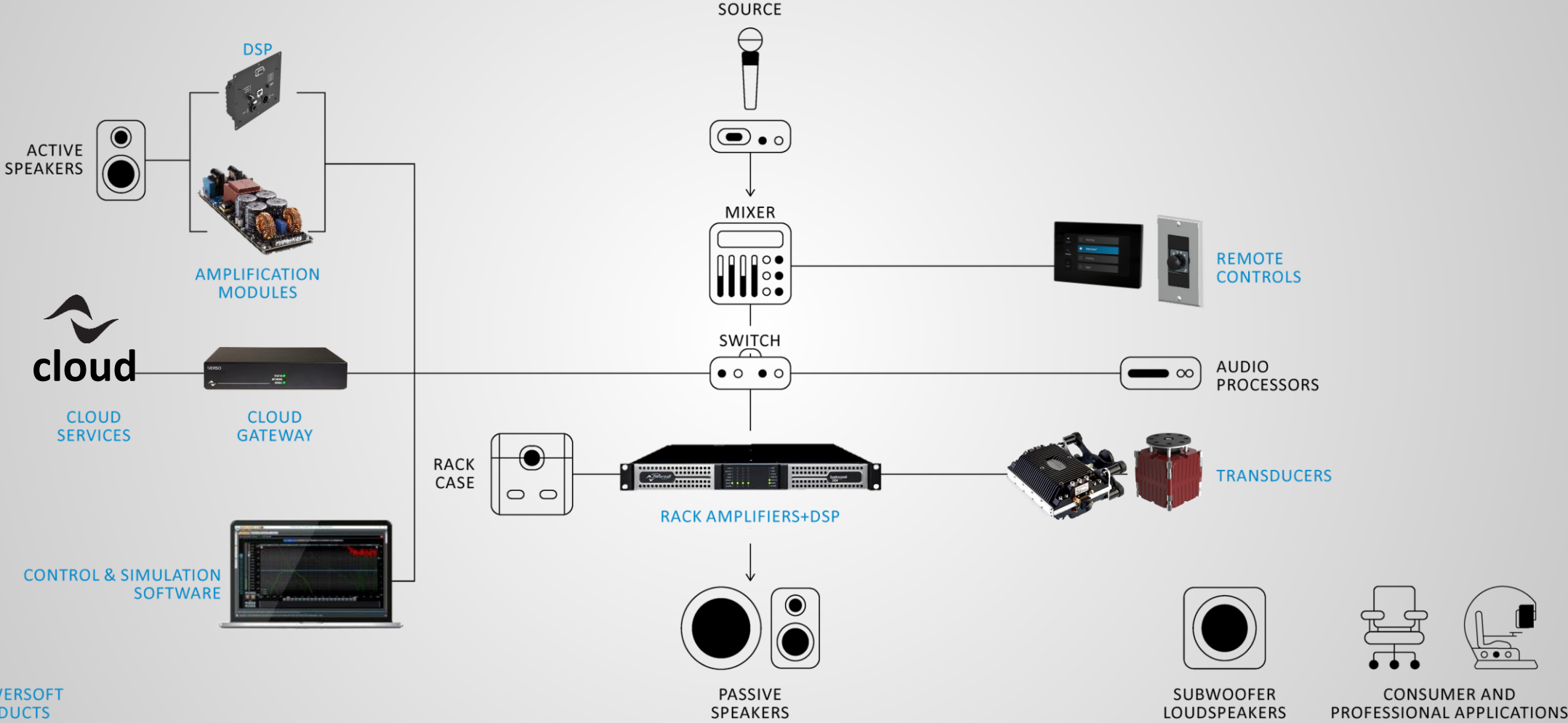

AT THE HEART OF THE PRO AUDIO SYSTEM



HW ARCHITECTURE

Unica 8M Internal Structure

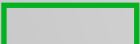
Unica are the last release amplifier platforms.

-  Signal Processing and control Section
-  Amp Section
-  Power conditioning and supply Section

PROCESSOR

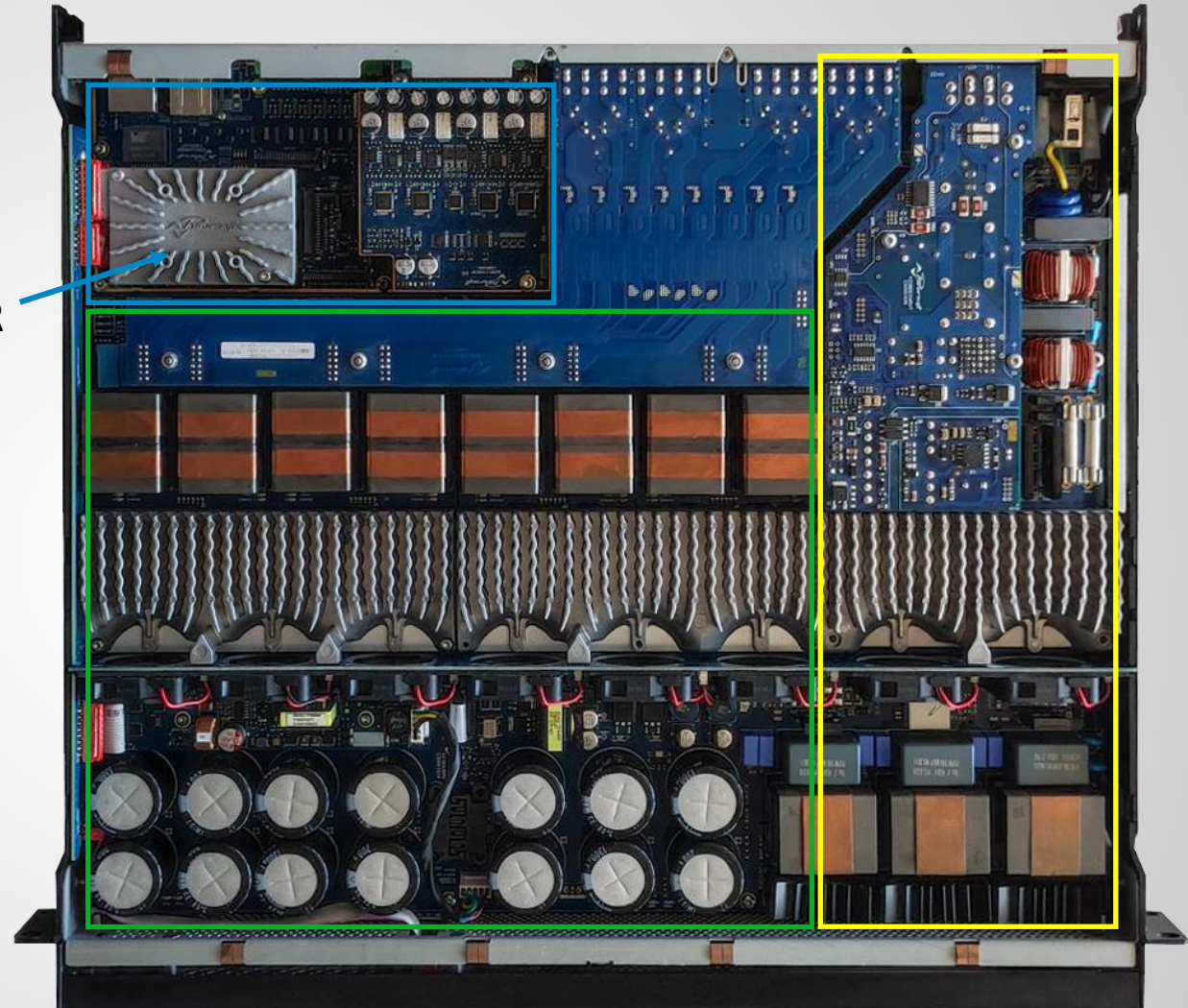

FRONT DISPLAY



TRANSDUCER APPLICATION

MOVER DD Integration components

Optimized platforms with suspension system for use with **Mover DD** models.

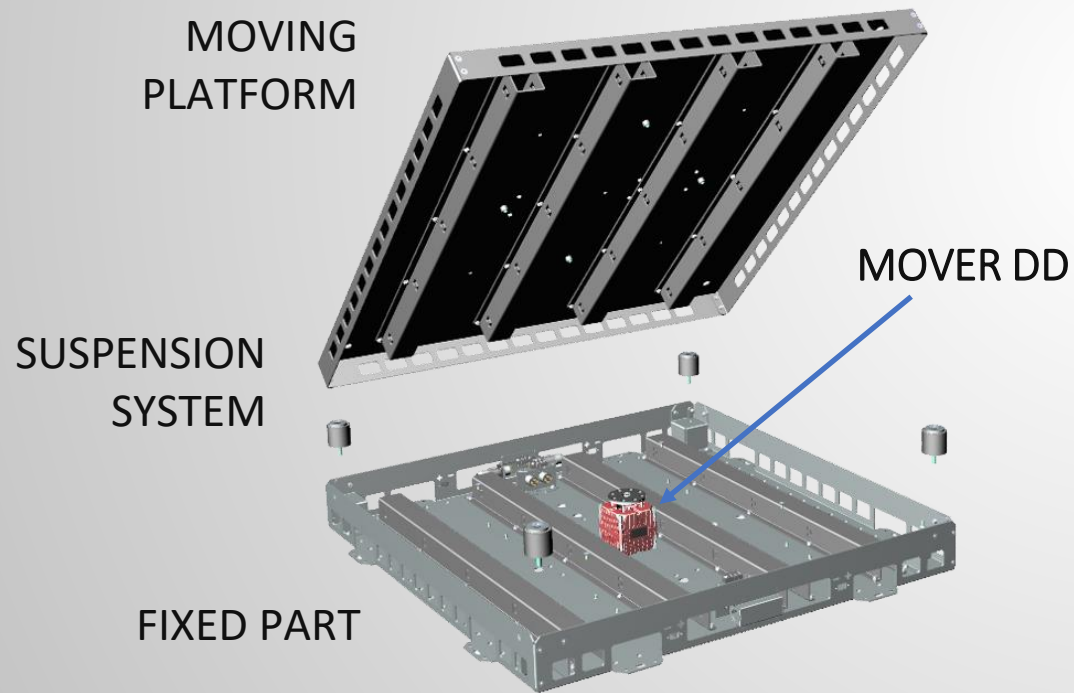

Immersive Dance Music Journey at Our House

Thanks to 64 Mover placed beneath the dance floor, visitors hear and feel the music, as low-end frequencies and haptic feedback synchronize with beats.



TRANSDUCER APPLICATION

M-Force – M SUB reference design

Together with industry professionals, we have worked on a set of designs to help you harness the power of the **M-Force**.

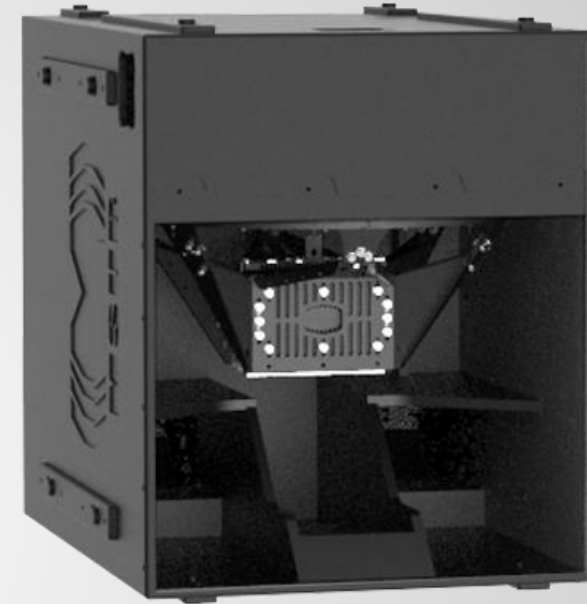
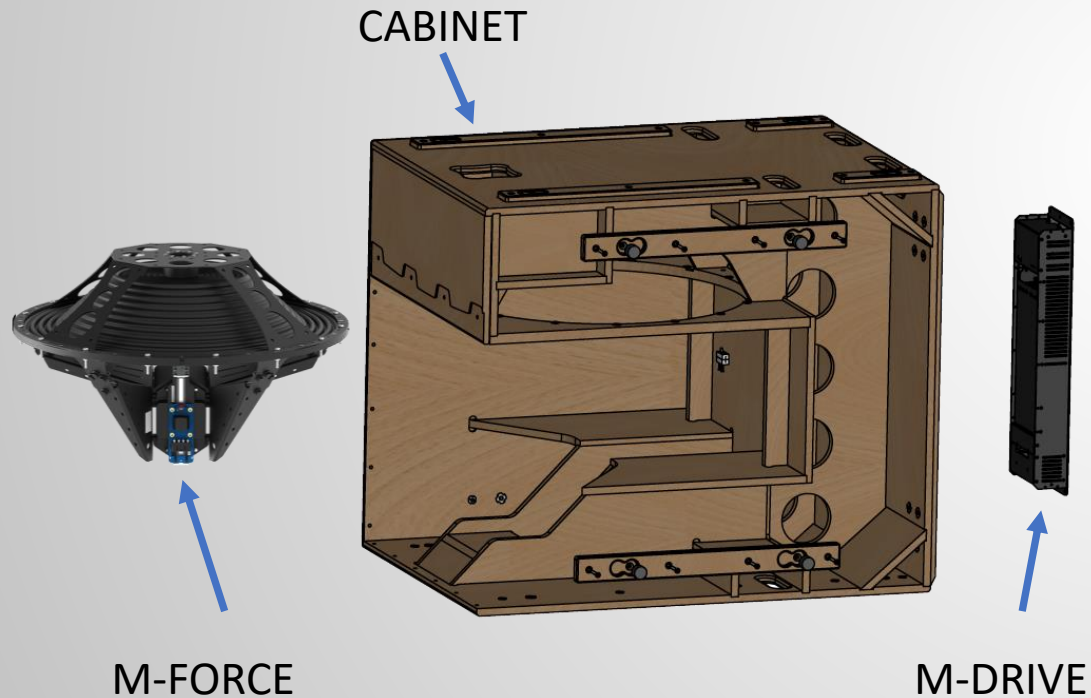

M SUB

The M SUB is a hybrid transmission line cabinet loaded with the M-Force transducer for infra and subwoofer applications. It can be used as a subwoofer or as infra add-on to your install or touring sound reinforcement system.



OUR PRODUCTS

SAFETY MULTIMEDIA DEVICES



DEVA

CONTROLLER



WM TOUCH

TRANSDUCERS



IPALMOD



M-FORCE



M-DRIVE

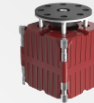

MOVER

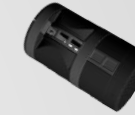

S-PIXEL



FLATFORCE

RACK AMPLIFIERS



Q SERIES/D SERIES*



DUECANALI SERIES



OTTOCANALI SERIES



MEZZO SERIES



QUATTROCANALI SERIES



TTM



UNICA



DIGAM 3000*



K SERIES



M SERIES



X SERIES



T SERIES

AMPLIFICATION MODULES



DIGIMOD



DIGIMOD PFC



D-CELL 504



DIGIMOD
PFC2/PFC4



DIGIMOD IS

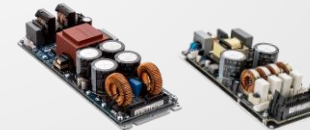

LITEMOD

MINIMOD



LOTO

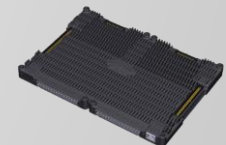

WFS

1995-2003

2004-2009

2010-2013

2014-2019

2020-2023



PRODUCTS AND SOLUTIONS



RACK
AMPLIFIER



OEM RACK
AMPLIFIER

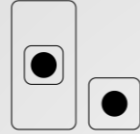

REMOTE
CONTROL



ACTIVE SPEAKER
AMPLIFIER



DSP SIGNAL
PROCESSING



BASS SHAKERS
TRANSDUCERS



SECURITY
MULTIMEDIA
DEVICE



DIAGNOSTIC
AND PROGNOSTIC
SERVICES

VS MARKETS

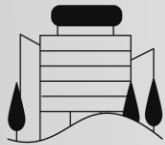

CORPORATE

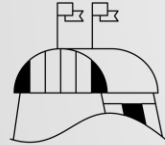

CONVENTION
& EXHIBITION
CENTERS



AIRPORTS



THEME PARKS

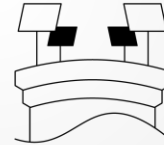

STADIUMS
& ARENAS

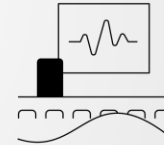

CONFERENCE
& BOARD ROOMS



EMERGENCY AND
SECURITY

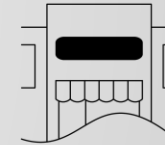

RETAIL



HOUSES OF
WORSHIP

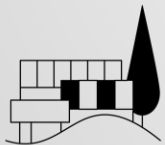

INDUSTRIAL



HOTELS &
RESORTS

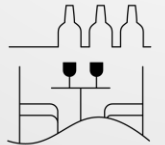

BARS &
RESTAURANTS

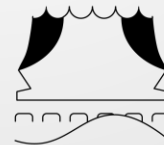

THEATRES



MUSEUMS



MALLS &
SHOPPING
CENTERS



CRUISE SHIPS



STRONG INTERNATIONAL PRESENCE

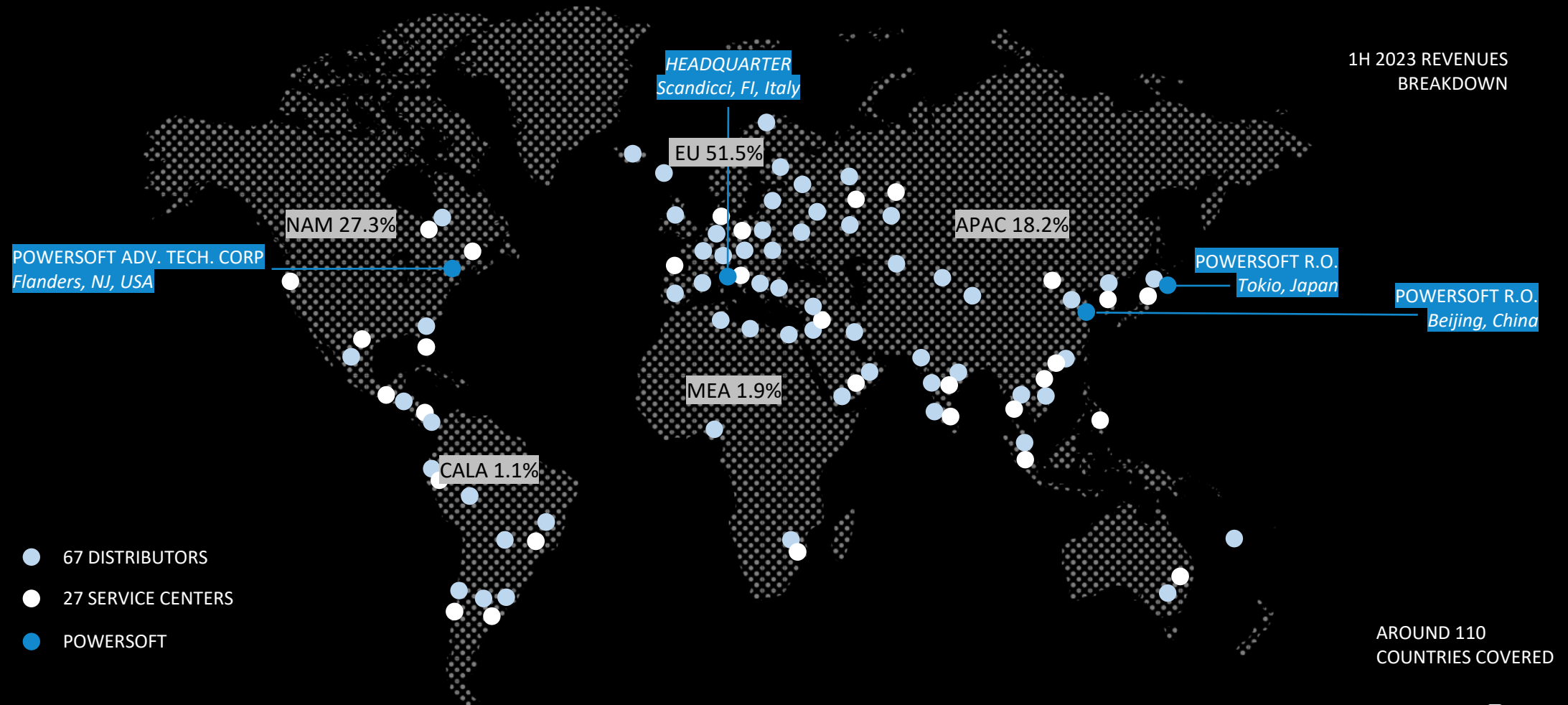

DIVERSIFIED AND EFFICIENT BUSINESS MODEL

CORE STRENGTHS

- **R&D Dept.** with a **strong focus on Innovation** and **product design** to address market requirements
- **Purchasing Dept.** with **high-level technical capabilities** and **smart supply chain management skills** to overcome shortage of components
- **Internal «Lean» Production Large production** allows capacity potential to address time to market requirements
- **Diversified sales network** to better enter each market segment

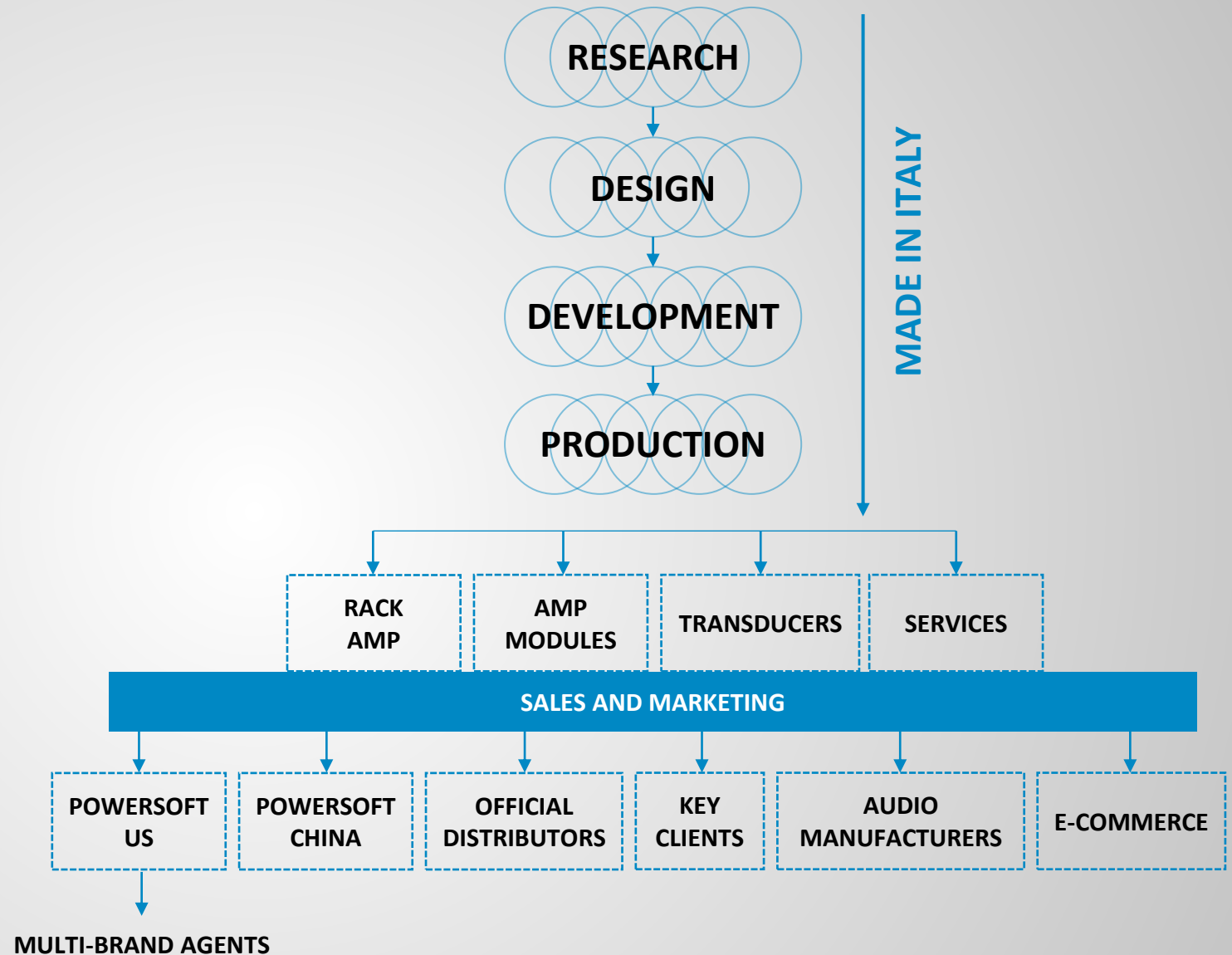

MADE IN ITALY

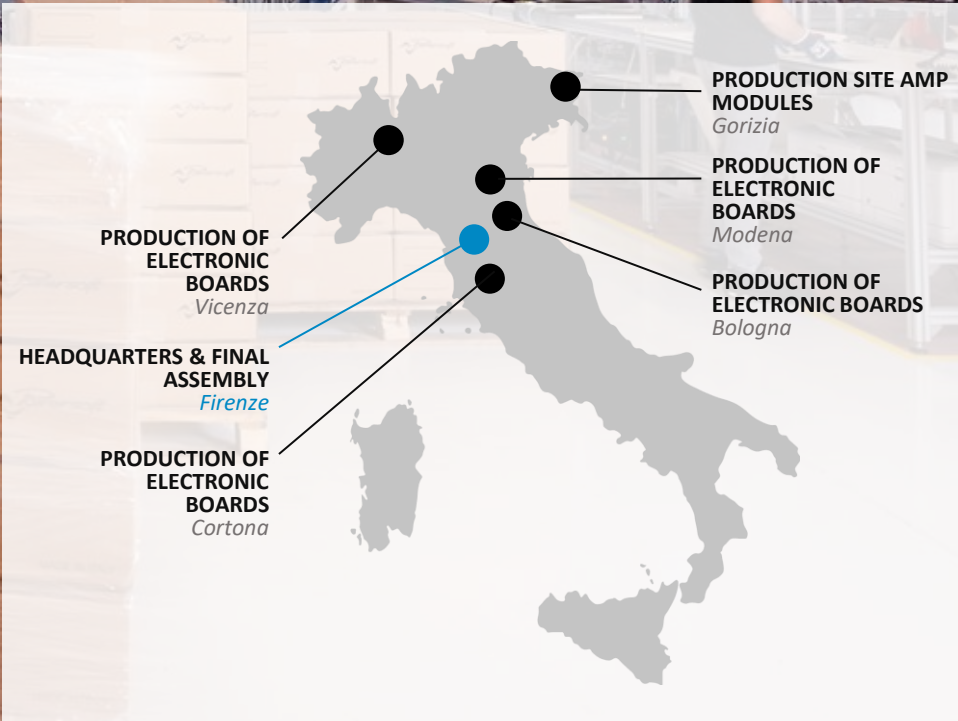



MARKET TREND AND STRATEGY



INCREASING FOCUS ON GROWING SEGMENTS

REFERENCE MARKET FOR TARGET APPLICATIONS STEADILY GROWING IN NEXT 7 YEARS EXPECTING TO EXCEED 1 BILLION EUROS BY 2030

- **Powersoft outperforming** vs market average in the past 3 years
- Company **stronger focus on installed business** allows **optimistic forecast** considering relevant market size and growth
- **Business opportunities** in immersive applications confirm brand strength and growing awareness in leisure installed vertical markets

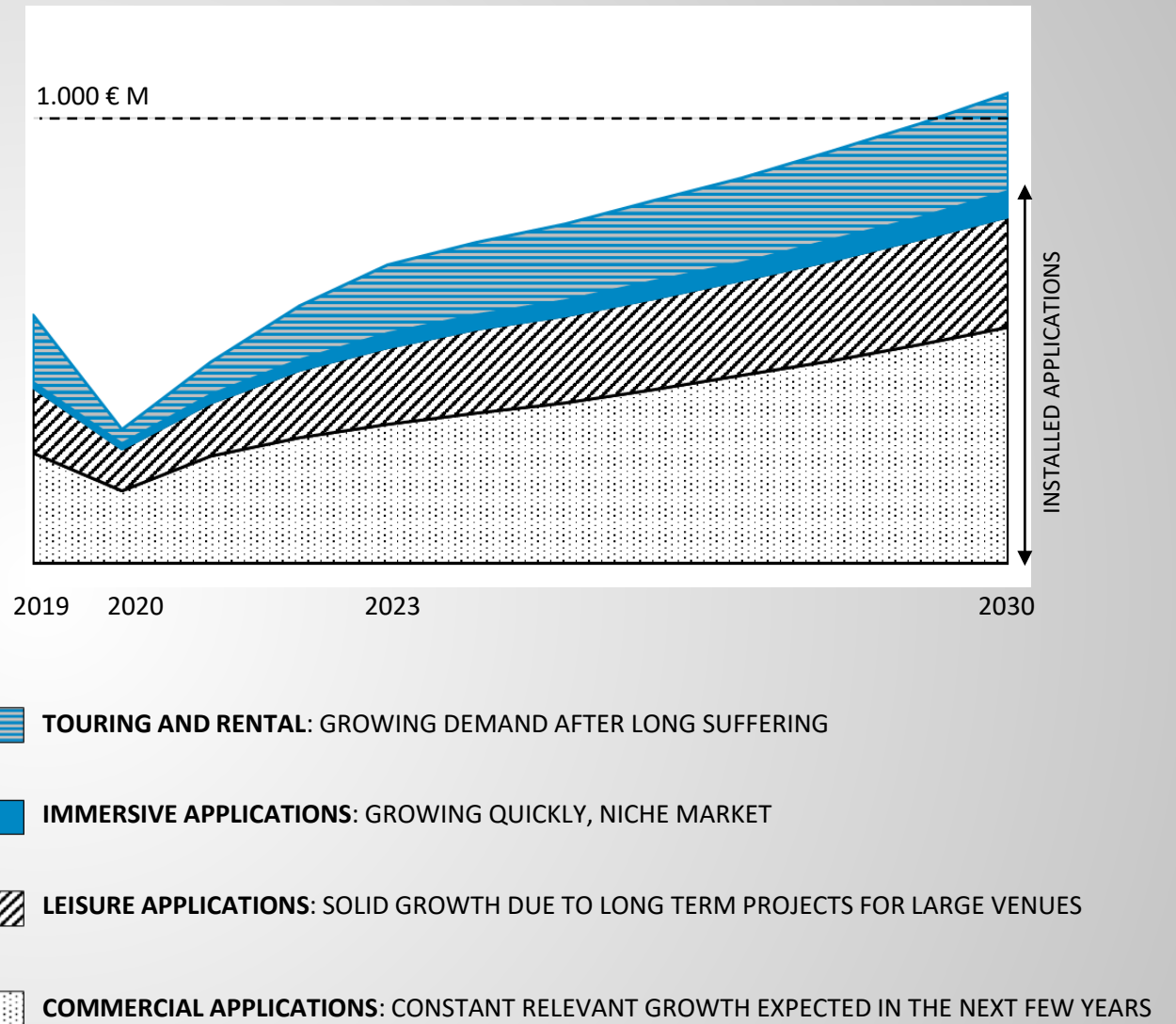

**Data is related to reference market for rack amplifiers and transducers (modules excluded)
Data source: Powersoft elaboration based on primary research panels*



A MARKET WITH ROOM FOR GROWTH AND CONSOLIDATION

Main market players for company size and level of vertical integration of products and offered services

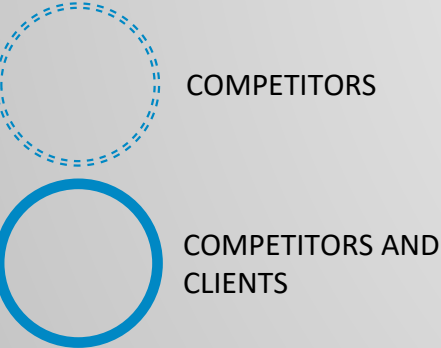

THREE PILLAR STRATEGY TO KEEP GOING AND KEEP GROWING



FOCUS ON INNOVATION AND NEW TECHNOLOGIES

- **Top level R&D** laboratory
- Powersoft's **Ideofarm growth accelerator** to support new projects and innovative technologies
- **Environmentally friendly products**
Small sizes, huge power, super efficiency

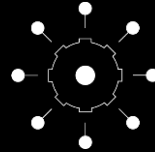

FROM PRODUCT COMPANY TO SOLUTION PROVIDER

- **Proprietary solutions** designed for specific target applications
- **Cloud-native IOT products** to offer custom-related services
- **Software** based services to exploit **upselling/cross-selling potential (UNIVERSO)**
- **Partnership** for the expansion of the product/service catalogue

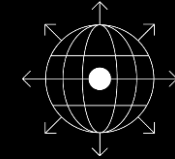

STRENGTHENING OF PRESENCE IN STRATEGIC MARKETS

- **Boost presence** in US, Canada and Latin America market
- **Direct presence in China, Japan, Middle East**
- **Partnerships** with strategic players to enter new markets





STRONG EQUITY STORY BACKED BY SOLID FINANCIALS



1H 2023 BEST EVER GROUP RESULTS KEY FACTS

Group's strategy of repositioning **from Product Company to Solution Provider is bearing fruits.**

All the main economic-financial aggregates in strong growth with margins that exceed pre-pandemic levels:

- Consolidated **Revenues** at **€ 33.1 M** (+68.0% YoY)
- **EBITDA** at **€ 8.6 M** (\approx +133.7% YoY), sound EBITDA margin equal to 26.5% from 19.2% in 1H 2022 (+730 bps)
- **Net Profit** at **€ 5.2 M** (+273.4% YoY)
- **Positive NFP** of € 15.0 M thanks to **strong operating cash flow generation**

Significant growth driven by both the Install sector and the pro-Audio sector in the main geographies where the Powersoft Group operates.

Bright outlook thanks to a double-digit **order book growth.**



FINANCIAL HIGHLIGHTS

A solid equity story and sound financials, which allows the company to face, with flexibility and speed, the changing commercial and industrial needs, and growth goals

REVENUES €/M

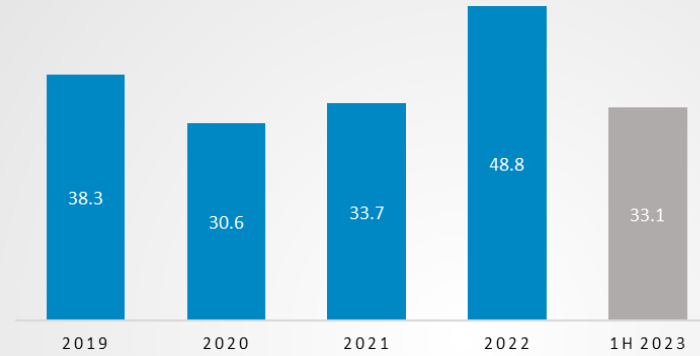

EBITDA €/M – EBITDA MARGIN %

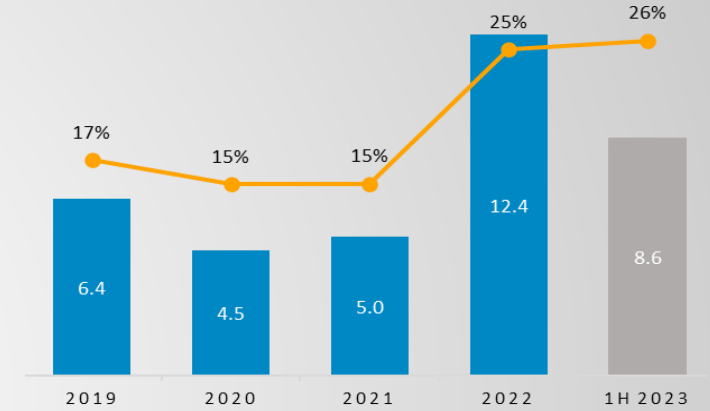

EBIT €/M – EBIT MARGIN %

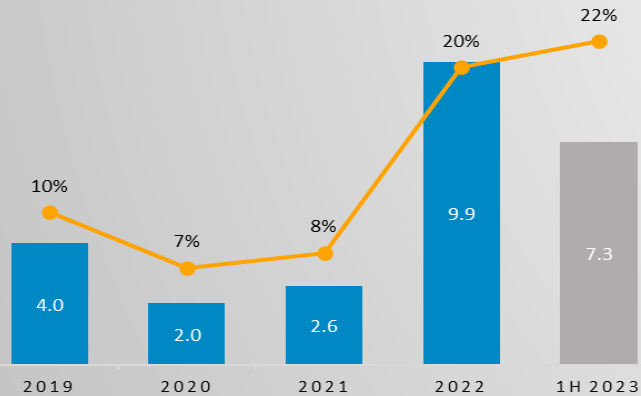

NET PROFIT €/M

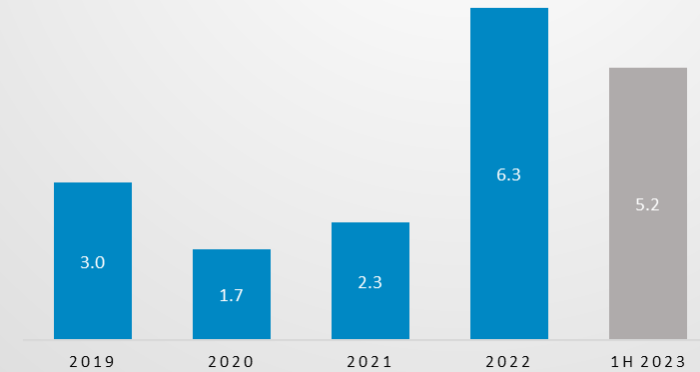

NFP (CASH) €/M

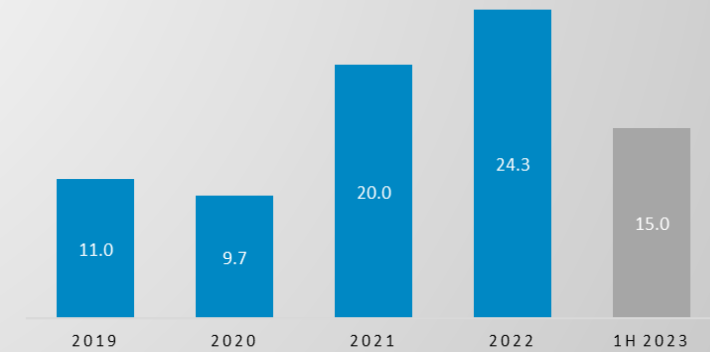

1H 2023 ROADSHOW

(1) Total revenues at 31/12/2020 have been restated to take into account the different recognition of €0.8 million of revenues related to the re-invoicing of raw materials in the Cost of Sales item.



FOCUS ON 1H 2023 RESULTS

TOTAL REVENUES €/M

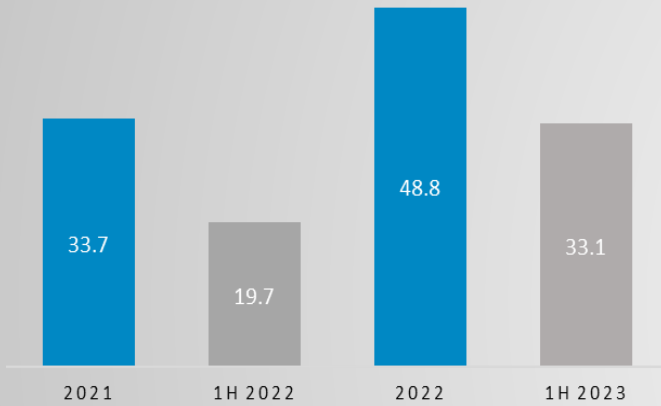

EBITDA €/M

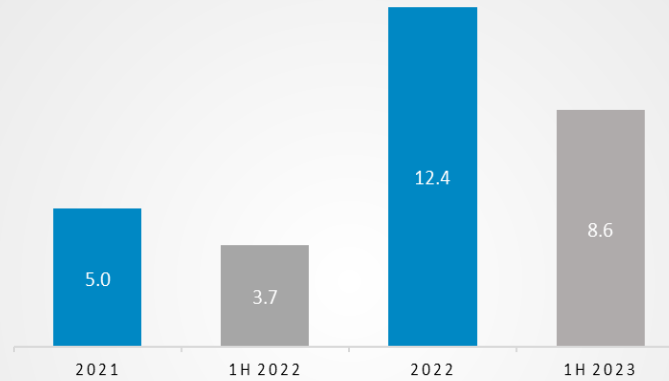

NET PROFIT €/M

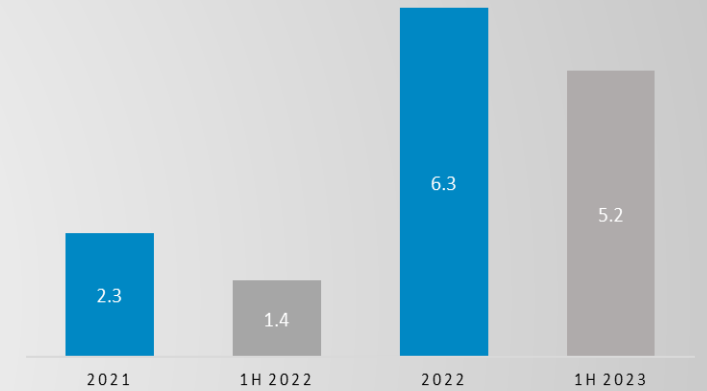

- Revenues at € 33.1 M, +68.0% YoY
- Growth in all geographies: North America (NAM) +57.2%, APAC +108.5% & Europe +68.1% YoY
- Wide visibility of the backlog

- EBITDA at € 8.6 M, +133.7% YoY & EBITDA margin at 26.5%
- The cost of goods up YoY due mainly to the increase in volumes sold
- Personnel costs increased as a sign of continuous investments aimed at pursuing company growth objectives and in particular to the increase in sales volumes

- Net Profit at € 5.2 M, +273.4% vs € 1.4 M in 1H 2022 with an incidence on turnover of 16.1%
- Lower financial charges in comparison to the first half of 2022



CONSOLIDATED EBITDA – EVOLUTION 1H 2022 - 1H 2023

€/M

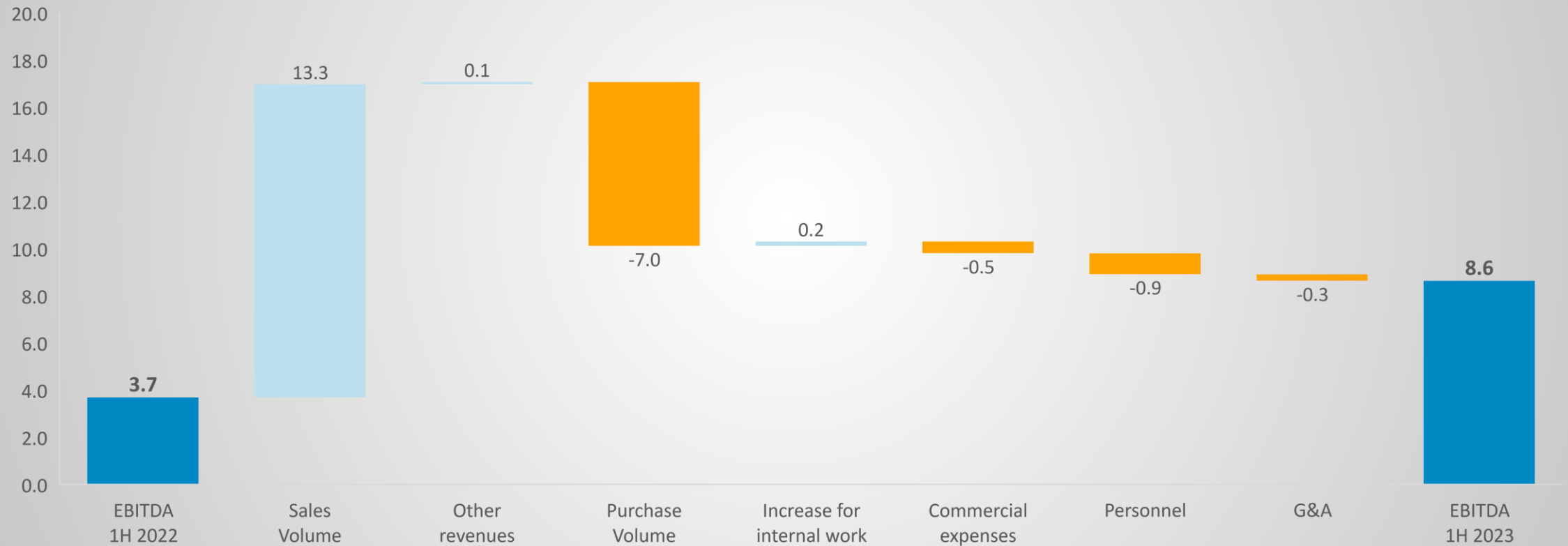

SOUND BALANCE SHEET

NET WORKING CAPITAL €/M

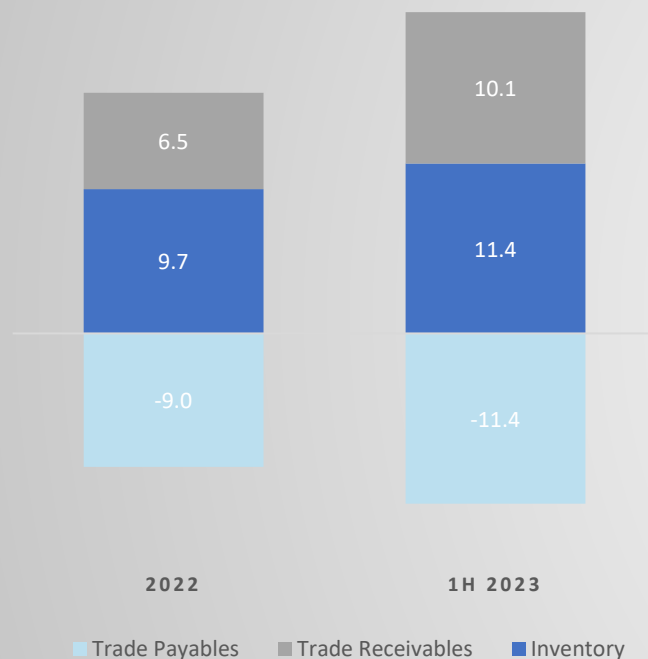

NWC up to € 8.7 M in 1H 2023 mainly due to the increase of trade receivables

NET FINANCIAL POSITION €/M

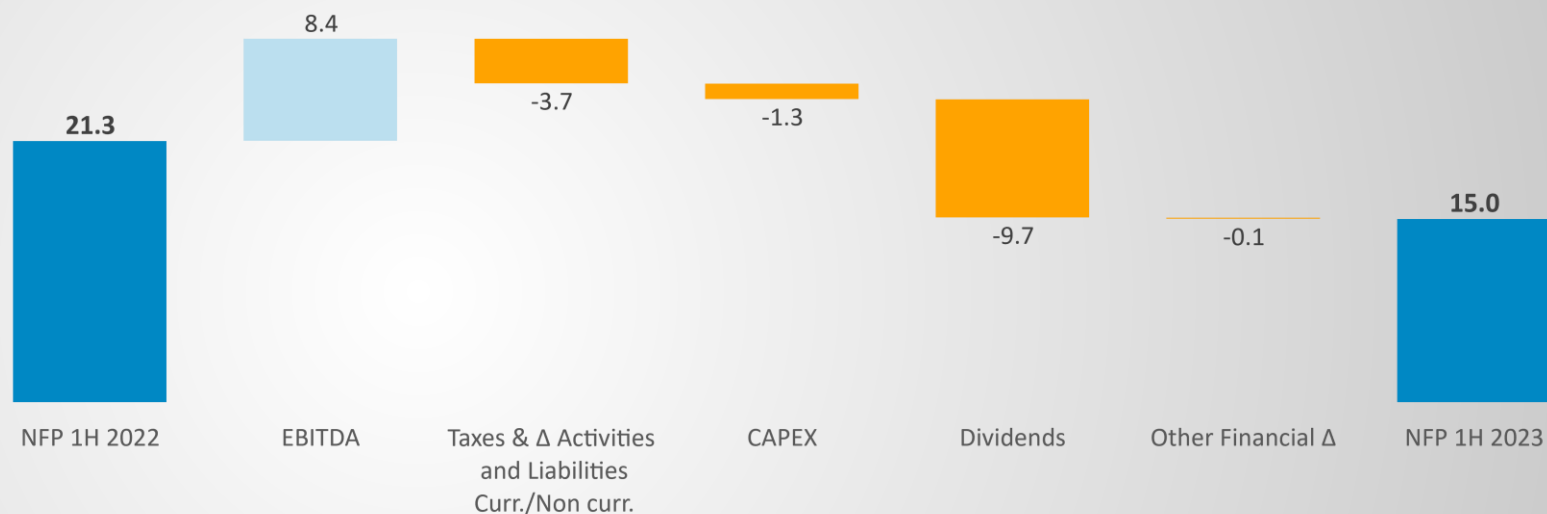

NFP at € 15.0 M, compared to € 21.3 M as of 30 June 2022, and mainly composed of:

- Cash and Cash Equivalents for € 14.1 M
- Securities in Portfolio for € 5.3 M
- Negative Items for € 4.5 M



KEY TAKEAWAYS

- **Successful repositioning** from Product Company to Solution Provider
- **Faster growth and strong competitive positioning** thanks to **R&D investments** in product innovation and offering expansion
- **Improving market share** in US and in APAC by strengthening traditional sales channels and the **development of new ones**
- **Partnerships** with industry players and opportunities for long-term organic growth
- **Large install projects** and audio immersive venues: potential add on





APPENDIX



GOVERNANCE

BOARD OF DIRECTORS



BOARD OF STATUTORY AUDITORS

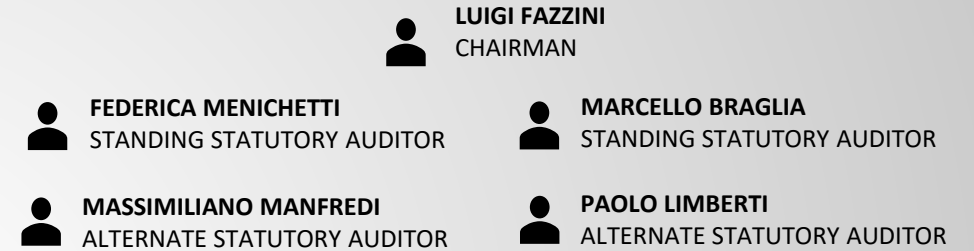

STOCK FIGURES

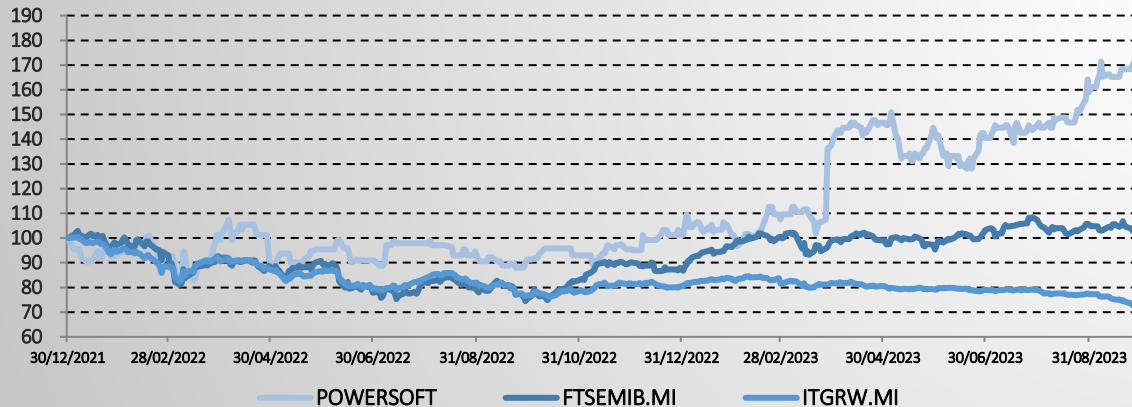

IPO: 17/12/2018
Shares: 11,796,212
Market: Euronext Growth Milan

Price (29/09/2023): € 8.50
Market Cap (29/09/2023): ≈€ 100 M
Average Daily Volume YTD: ≈ 6.2 K

AUDIT FIRM



SHAREHOLDINGS AND GROUP ORGANIZATION CHART

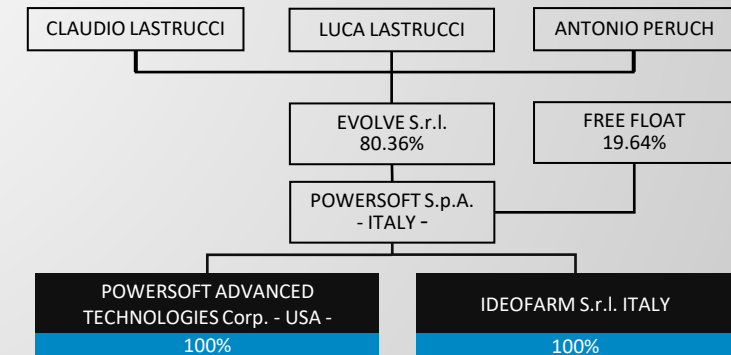

NOTABLE ARTISTS AND FESTIVALS WHO CHOOSE US

- AC/DC
- Andrea Bocelli
- Beyoncé
- Black Eyed Peas
- Bruno Mars
- Calvin Harris
- Caparezza
- Coldplay
- David Guetta
- Drake
- Ed Sheeran
- Elton John
- Eminem
- Foo Fighters
- Iron Maiden
- Jamiroquai
- Jay-Z
- Justin Timberlake
- Katy Perry
- Kendrick Lamar
- Lady Gaga
- Laura Pausini
- Madonna
- Martin Garrix
- Metallica
- Muse
- Radiohead
- Red Hot Chili Peppers
- Shawn Mendes
- Sia
- Taylor Swift
- The Rolling Stones
- The Weeknd
- U2
- Vasco Rossi
- Zucchero
- Burning Man
- Coachella
- Electric Daisy Carnival
- Eurovision Song Contest
- Glastonbury Festival
- Les Dunes Electroniques
- Lollapalooza
- Rock in Rio
- Rockin' 1000
- Roskilde Festival
- Tomorrowland
- Ultra Music Festival
- And many more...



SOME OF OUR INSTALLATIONS AROUND THE WORLD

- Allianz Arena
- Arena Corinthians
- Audi Dome
- Beijing National Stadium
- Beiteddine Palace
- Burberry
- CERN
- City of Dreams
- Club Cubic
- Domino's Pizza
- Dortmund Stadium
- Estadio BBVA Bancomer
- Fiserv Forum
- Gelora Bung Karno Stadium
- Google Campus
- Grand Theatre de Quebec
- Hard Rock Stadium Miami
- La Cigale
- Las Vegas Sphere
- Madison Square Garden
- McDonald's
- Mercedes-Benz Stadium
- NRG Stadium
- Pala Alpitour
- PPG Paints Arena
- Qudos Bank Arena
- Red Bull Arena
- Royal Albert Hall
- Royal Danish Opera House
- Sapporo Dome
- Scotiabank Arena
- Singapore Sports Hub
- Staples Center
- Sydney Opera House
- T-Mobile Arena
- Wembley Stadium
- And many more...





BASE NIGHTCLUB
DUBAI, UAE

MUSIC CLUB SYSTEM

CHALLENGE:

Open-air nightclub with the requirement to complete the project in 23 days.

SOLUTION:

9x X4 DSP + ETH to save on power consumption and gain amplification output.

RESULT:

Powersoft provided the most cost-efficient power solution per channel, with much simpler configuration requirements than competing products.



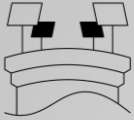

PARC OLYMPIQUE LYONNAIS STADIUM
LYON, FR

STADIUM SYSTEM

CHALLENGE:

To serve the 59,000-seat stadium with a pristine and broadcast quality sound reinforcement system.

SOLUTION:

4x **Ottocanali 4K4** and 14x **Ottocanali 12K4** taking analogue feeds from Symetrix matrix router's Dante extension cards.

RESULT:

"When people come to this stadium, they get a real show, both visually and sonically. The result is a great installation for football fans which will resonate in the years to come."

- Nicolas Houel, Technical Manager at OL Images



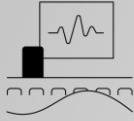

HANA HOLMEN
ESPOO, FI

CULTURAL CENTER

CHALLENGE:

To deliver a high-quality sound system for multi-purpose spaces with a dedicated platform for control and monitoring.

SOLUTION:

Quattrocanali DSP+D and **Duecanali DSP+D**

RESULT:

Customer satisfaction due to amplifier's ease of use and reliability.



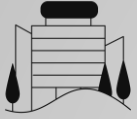

CROSS CAMPUS
LOS ANGELES, USA

WORK SPACE SYSTEM

CHALLENGE:

A new system for Cross Campus co-working space, to be as networked and automated as possible, in such a way as not to require having a designated sound engineer present for the vast majority of events.

SOLUTION:

2x **Ottocanali DSP+D**, full system tuning with ArmoniaPlus, Dante connectivity and Symetrix integration.

RESULT:

“Powersoft is the only amp manufacturer that would have allowed me to provide the network and DSP functionality this job required while maintaining a healthy, great sounding system.”

- Matt Grossman, Hollywood Sound Systems

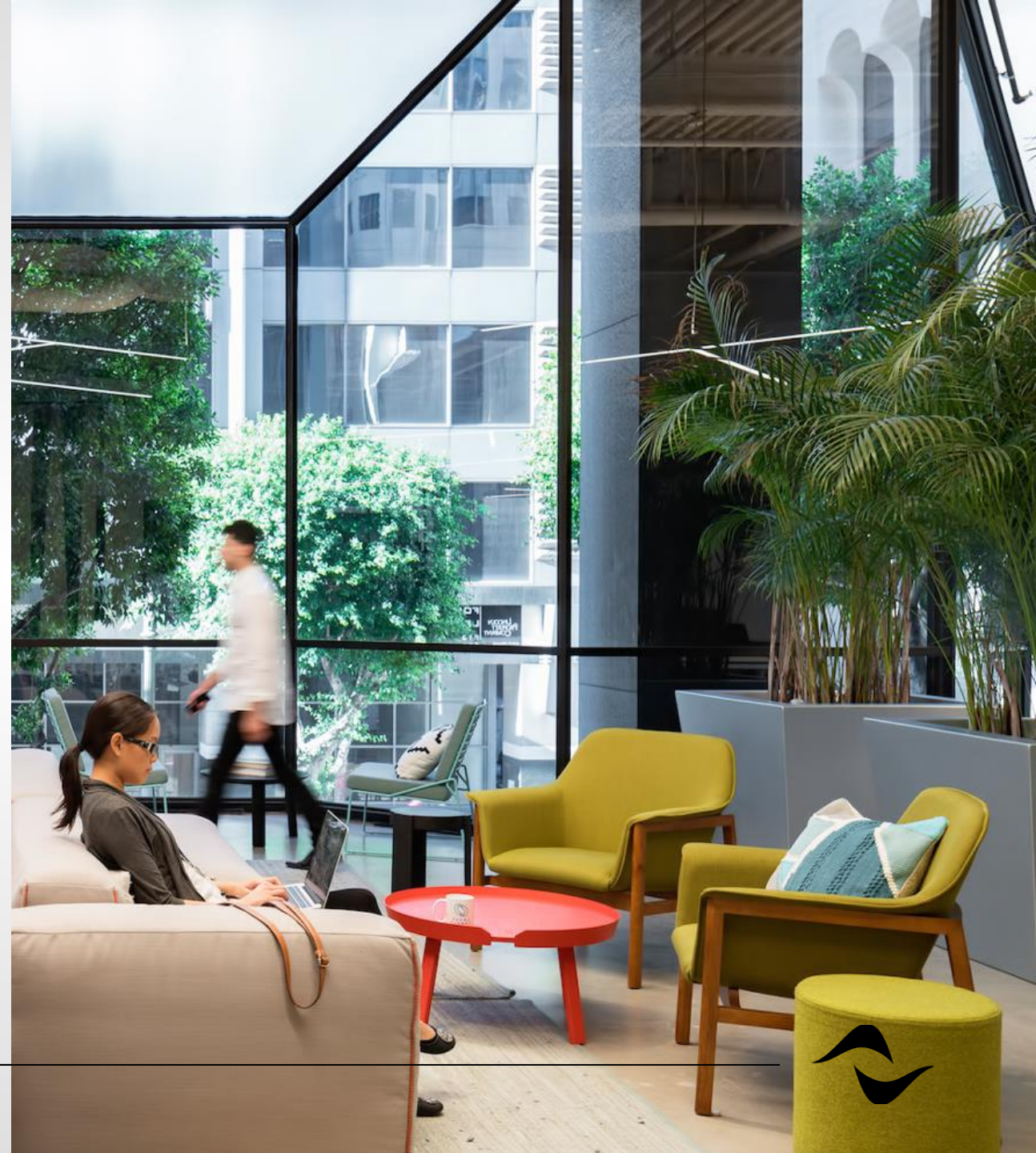



DIAGONAL MAR SHOPPING CENTER
BARCELONA, ES

SHOPPING CENTRE SYSTEM

CHALLENGE:

A competitive Dante enabled solution for a combination of Hi and Lo-Z speakers distributed in different zones.

SOLUTION:

4x **Ottocanali DSP+D** and 2x **Quattrocanali DSP+D** with full Dante-Symetrix integration.

RESULT:

Flawless system performance and end customer satisfaction.



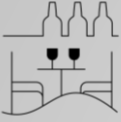

YARD HOUSE RESTAURANT DENVER, USA

RESTAURANT SYSTEM

CHALLENGE:

A reliable and efficient system for background music, night after night. To reduce rack space and installation costs.

SOLUTION:

5x **Quattrocanali** units to replace 12x 2-channel amplifiers mixing Lo-Z and 70-Volt distributed line loads.

RESULT:

Reliable and high-power system with zero service required. Saving on racks, cabling and operational costs.



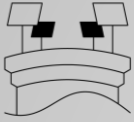

UNIVERSITY OF NEVADA - MACKAY STADIUM
RENO – NV, USA

STADIUM SYSTEM

CHALLENGE:

To provide an amplification solution for the 30.000-seat arena, with low power consumption requirements and low heat dispersion, due to high summer temperatures.

SOLUTION:

4x **Ottocanali 8K4** to replace 12x 3RU pre-existing amplifiers.

RESULT:

"These amplifiers hit a lot harder than others on the market. The sound and clarity was amazing. One of the first comments came from one of the executives asking if we had installed subwoofers in the system, which of course, we hadn't."

- Nathan Barlow, Pro AV & Electronics





UNIVERSITY OF NEVADA - MACKAY STADIUM
RENO – NV, USA

HOTEL SYSTEM

CHALLENGE:

A reliable and efficient system to cover background music night after night, while providing sufficient power and headroom for volume boost in DJ nights and special events.

SOLUTION:

1x **Ottocanali 4K4** for the open-air lounge, and **1x M30D** and **1x 4K4 Ottocanali** and for the penthouse hi-fi sound system.

RESULT:

“The sound quality of Powersoft is second to none, but we also choose Powersoft because of the consistency and reliability”



DISCLAIMER

“This Presentation contains certain forward-looking statements. Forward-looking statements concern future circumstances and results and other statements that are not historical facts, sometimes identified by the words "believes," "expects," "predicts," "intends," "projects," "plans," "estimates," "aims," "foresees," "anticipates," "targets," and similar expressions. The forward-looking statements contained in this Presentation, including assumptions, opinions and views of Powersoft S.p.A. (“**Powersoft**” or the “**Company**”) or cited from third party sources, are solely opinions and forecasts reflecting current views with respect to future events and plans, estimates, projections and expectations which are uncertain and subject to risks. Market data used in this Presentation not attributed to a specific source are estimates of the Company and have not been independently verified. These statements are based on certain assumptions that, although reasonable at this time, may prove to be erroneous. By their nature, forward-looking statements involve a number of risks, uncertainties and assumptions that could cause actual results or events to differ materially from those expressed or implied by the forward-looking statements. If certain risks and uncertainties materialize, or if certain underlying assumptions prove incorrect, the Company may not be able to achieve its financial targets and strategic objectives. A multitude of factors which are in some cases beyond the Company’s control can cause actual events to differ significantly from any anticipated development. Forward-looking statements contained in this Presentation regarding past trends or activities should not be taken as a representation that such trends or activities will continue in the future. No one undertakes any obligation to update or revise any forward-looking statements, whether as a result of new information, future events or otherwise. Market data used in this Presentation not attributed to a specific source are estimates of the Company and have not been independently verified. Forward-looking statements speak only as of the date of this Presentation and are subject to change without notice. No representations or warranties, express or implied, are given as to the achievement or reasonableness of, and no reliance should be placed on, any forward-looking statements, including (but not limited to) any projections, estimates, forecasts or targets contained herein. Powersoft does not undertake to provide any additional information or to remedy any omissions in or from this Presentation. Powersoft does not intend, and does not assume any obligation, to update industry information or forward-looking statements set forth in this Presentation. This presentation does not constitute a recommendation regarding the securities of the Company.

This Presentation is not an offer, or a solicitation of an offer, to buy, sell or exchange any securities in Italy, pursuant to Section 1, letter (t) and letter (v) of Legislative Decree no. 58 of February 24, 1998, or in any other country or state and is not a prospectus or an offer document within the meaning of Italian laws and regulations.

It should be noted that the audit of the Draft Financial Statements has not yet been finalised and that the Independent Auditors' Report will therefore be made available within the terms required by law. It should be also noted that Income Statement and Balance Sheet shown in this Presentation are reclassified and not subject to audit by the Independent Auditors.”





Powersoft S.p.A.
Via Enrico Conti,5
50018 Scandicci

 www.powersoft.com



Euronext Growth Advisor
Banca Finnat
+39 39 06 69933215

Specialist
Banca Profilo S.p.A.
+39 02 584081

Corporate Broker
Alantra Capital Markets
+39 02 63671601



IR Manager
Massimo Ghedini
ir@powersoft.com
Ph. +39 055 7350230

IR Advisor
Vincenza Colucci – CDR Communication
vincenza.colucci@cdr-communication.it
M. +39 335 6909547
Eleonora Nicolini – CDR Communication
eleonora.nicolini@cdr-communication.it
M. +39 333 9773749

