

MOVER

Low frequency direct drive / tactile transducer

The MOVER is a patented low-frequency direct drive/tactile transducer.

Through haptic perception, the human body can pick up the most minute vibrations, and bone conduction stimulates the inner ear which translates these into perceivable frequencies, thus allowing for deeper, richer sound experiences.

Despite its compact design, the MOVER packs a serious punch, allowing for scalability in larger projects, as well as miniaturization in more circumscribed setups.

Its uses are not confined to the audio realm: vibrating floors and warning systems are examples of other possible applications.

The MOVER is extraordinarily efficient, meaning that it can be easily coupled with a surface, to work its magic.

For more efficiency and more dramatic effects, it can also be used in direct drive applications. Here it is anchored to an immovable surface, and the moving magnet is connected to a movable surface, such as a floating floor or a chair.

As an example; 4 motors in parallel can drive a platform with 4 persons using a total power of 100 W at 5 Hz to simulate riding a bus.

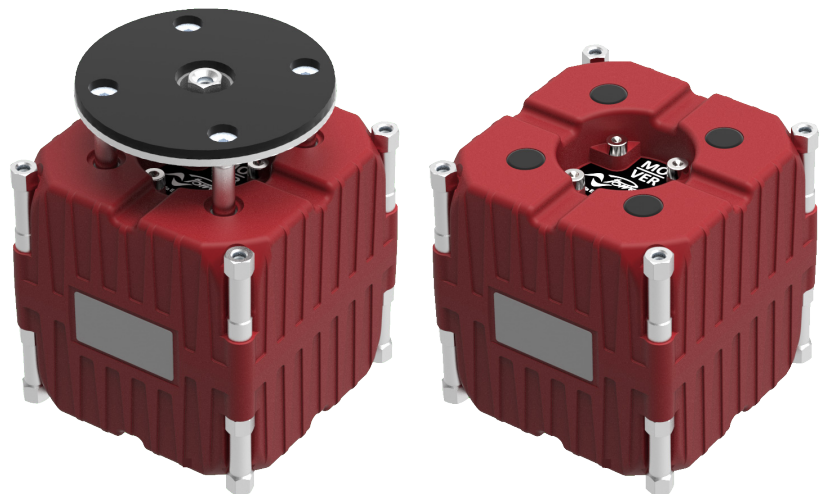

- ▶ 4D cinemas
- ▶ High end home cinemas
- ▶ Vibrating acoustic floors
- ▶ Theme parks
- ▶ Gaming
- ▶ Industrial applications

- ▶ Very high power tactile transducer.
- ▶ High efficiency.
- ▶ High mechanical power.
- ▶ High-quality magnet
- ▶ Very high ratio between moving mass and total mass.
- ▶ Compact design.
- ▶ Ultra-Low frequency extension.
- ▶ DC moving capabilities
- ▶ No mounting plane limitations.
- ▶ Adaptable for various purposes.
- ▶ Two versions available with different impedances, depending on usage conditions.
- ▶ External coupler allows to connect the transducer's moving mass to the receiving surface.
- ▶ Thermal protection: internal thermal switch.



MOVER

Low frequency direct drive / tactile transducer

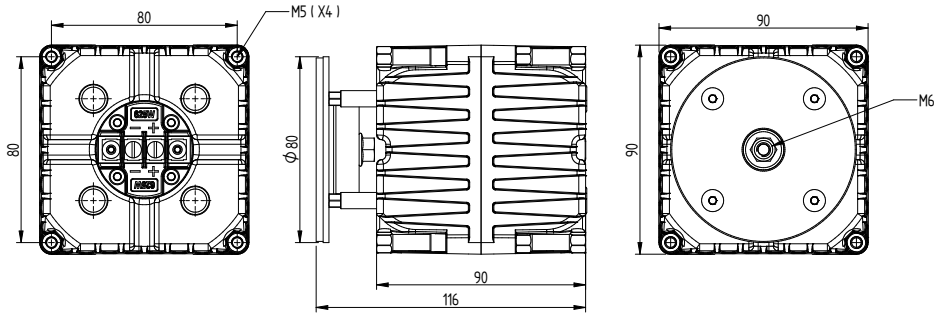

Specifications

Electromechanical parameters - 4 Ω Low Z Version		Electromechanical parameters - 16 Ω 100 V Version	
Moving Mass	1.20 kg 2.65 lb	Moving Mass	1.20 kg 2.65 lb
Peak mass displacement	± 10 mm ± 0.39 in	Peak mass displacement	± 10 mm ± 0.39 in
Magnet type	Neodymium grade 50 MGOe	Magnet type	Neodymium grade 50 MGOe
Magnet weight	280 g 10 oz	Magnet weight	280 g 10 oz
Nominal Impedance	4 Ω;	Nominal Impedance	16 Ω
DC Resistance	3.6 Ω	DC Resistance	9.7 Ω
Inductance @100 Hz	9.1 mH	Inductance @100 Hz	25.8 mH
Nominal BI	32 Tm	Nominal BI	52 Tm
Motor strength (BI) ² /Re	282 (Tm) ² /Ω	Motor strength (BI) ² /Re	282 (Tm) ² /Ω
Frequency response	0 - 500 Hz	Frequency response	0 - 500 Hz
Program power	25 - 625 W	Program power	25 - 625 W
Peak Power	1250 W	Peak Power	1250 W
Peak force (1250 W)	900 N 200 lbf	Peak force (1250 W)	900 N 200 lbf
Force factor (@1 W, DC coupled)	20 N/W 4.5 lbf/W	Force factor (@1 W, DC coupled)	20 N/W 4.5 lbf/W
Mechanical parameters			
Nominal Size (D x W x H)	90 x 90 x 90 (114*) mm 3.54 x 3.54 x 3.54 (4.5*) in		
Weight	2.44 kg 5.38 lb		

*Direct drive hardware version

Application Examples

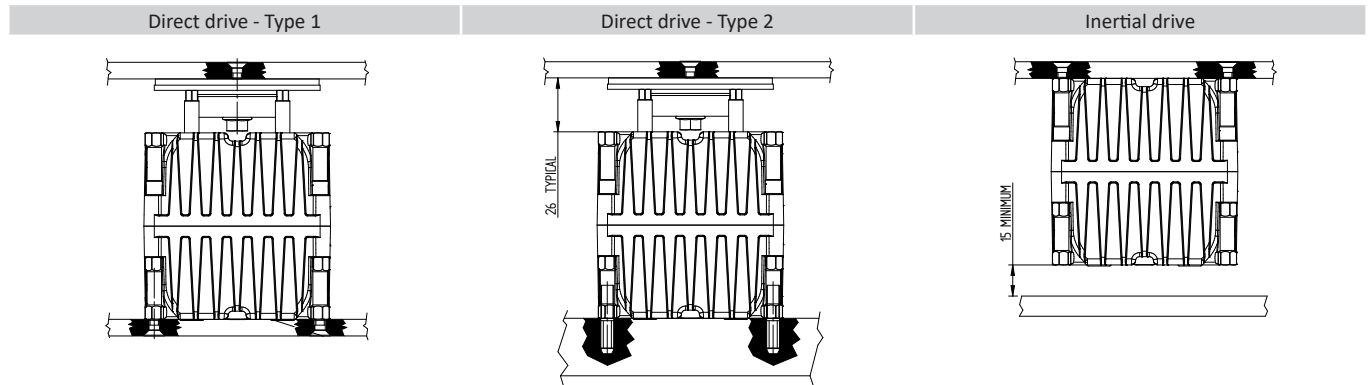

Please note that the portrayed configuration examples do not cover all possible applications. Power ratings could vary depending on acoustic design and specifications. Contact Powersoft for support in selecting the ideal solution for your specific needs. Data subject to change without notice

