



APPLICATION NOTES

GPIO

Contents

1	MEZZO	3
1.1	Overview.....	3
1.1.1	Allowable Voltage Ranges.....	3
1.1.2	Status Contact Closure.....	3
1.1.3	VCA Control	4
1.2	Generic Integration With Emergency-Mute Contact Closures.....	5
2	CANALI.....	7
2.1	Overview.....	7
2.1.1	Allowable Voltage Ranges.....	7
2.1.2	Alarm	7
2.1.3	VCA Control	8
2.1.4	Remote On/Off (Standby).....	8
2.2	Generic Integration With Emergency-Mute Contact Closures.....	9
2.2.1	Utilising Remote On/Off	9
2.2.2	Utilising VCA	10
3	UNICA	12
3.1	Overview.....	12
3.1.1	Allowable Voltage Ranges.....	12
3.1.2	Status Contact Closure.....	12
3.1.3	Stand-by	12
3.1.4	Master VCA.....	13
3.1.5	Configurable GPIO	14
3.2	Generic Integration with Emergency-Mute Contact Closures	15
4	Integration with Dynamic Music Distribution	17
4.1	Zone Level and Source Select Application Examples	17
4.1.1	Implementation in Armonia+	18
4.2	Stand-by and Priority Source Select Application Examples.....	18
4.2.1	Implementation in Armonia+	19
5	Application Examples for Common Combinations.....	22
5.1	Canali + Mezzo N/C Emergency Mute	22

All Powersoft rack-mountable installation amplifiers feature a GPIO section. The feature set differs from model to model, and so this document is divided by amplifier family initially (Sections 1 through 3), and then the families are grouped together with the Dynamic Music Distribution GPIO implementation (Section 4) and examples of common combinations of models are provided at the end (Section 5). Methods for implementing the most common applications are detailed in this document as both electrical wiring schematics and implementation examples. The implementation examples utilize DIN rail terminal blocks to aid with real-world implementation of the proposed electrical wiring schematic.

For those unfamiliar with DIN rail terminal blocks - they are available from many different manufacturers, in many different formfactors, and with many different feature sets. The examples provided in this document are based on the WAGO 2002-12 as this is an extremely common variety with a very basic feature set. They have a straight-through connection and two jumper-pin locations that are utilized to link two or more terminal blocks together.

For example, the Normally-Open Emergency Mute example for the Mezzo shown in Figure 1 would be implemented using one 5-pin jumper across 5 terminals as shown in the rendering in Figure 2.

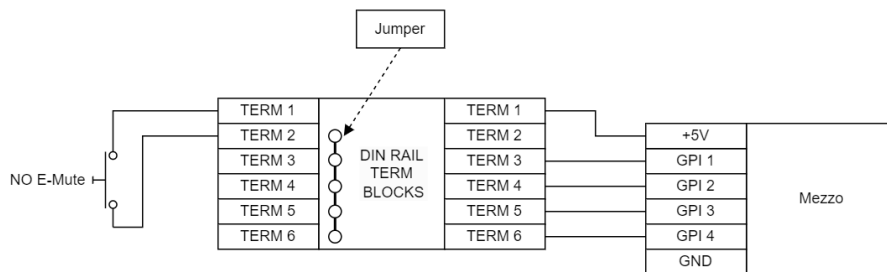

Figure 1 – Mezzo Normally-Open Emergency Mute

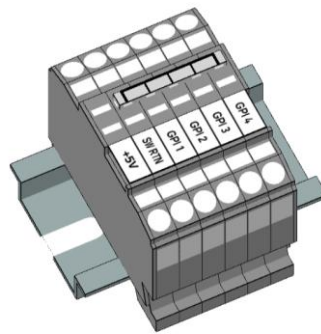

Figure 2 – Mezzo Normally-Open Emergency Mute DIN-Rail Block

Many other suppliers of DIN rail terminal blocks are available – please use the version most suitable for your project. Powersoft does not require the use of DIN-rail terminal blocks for implementation of GPIO functionality. The examples provided here are designed to help make your installation and planning process quicker and simpler.

1 MEZZO



Figure 3 – Mezzo 602 AD GPIO Section

1.1 Overview

The Mezzo GPIO is split into two sections, the right-hand side features a symbol of a switch. This is a contact closure that closes in the event of an amplifier or channel fault (including pilot tone monitoring faults). The left-hand side features pins for GPI use. Ground and +5V surround the main GPI pins.

1.1.1 Allowable Voltage Ranges

Mezzo GPI is designed for 0-5VDC only.

The contact closure is rated for up to 48V.

1.1.2 Status Contact Closure

The pins labelled with a switch icon connect to a contact closure that closes in the event of an amplifier or channel fault (including pilot tone monitoring faults). This is used to report amplifier status to a control system that does not implement the control and monitoring over the network.



Figure 4 – Mezzo contact closure connection

This is a normally closed connection. Under normal operation the relay is closed and will open upon a fault condition such as:

- No AC Mains
- Over temperature
- Amplifier in standby
- Loss of Pilot Tone
- Output monitoring fault
- Channel Faults

1.1.3 VCA Control

In the most basic default state of the amplifier, the GPI pins operate as VCA controls for the channel output levels. For more flexible GPI features with a Mezzo please see Section 4 for details on GPI integration with a DMD system.

Figure 5 shows the basic circuit diagram of a potentiometer controlling the VCA of Channel A of a Mezzo. +5V on the input pin results in the channel fully off, 0V on the input pin is fully open.

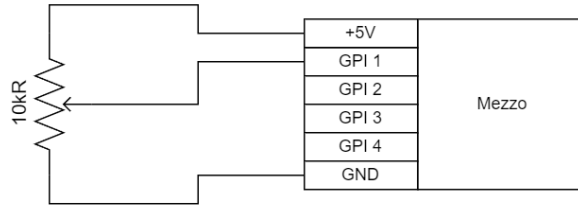

Figure 5 – Mezzo VCA Circuit

Figure 6 expands on this circuit diagram with an application example showing 3 potentiometers connected to a bank of terminal blocks utilizing jumpers to link the +5V and GND connections. Potentiometers 1 and 2 control the output levels of channels A and B respectively, but the third potentiometer controls the level of both channels C and D.

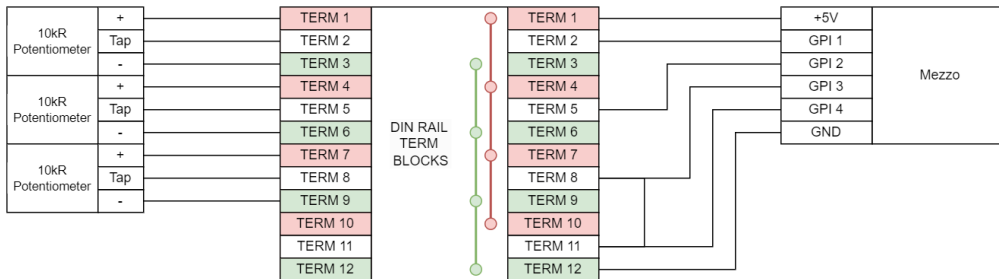

Figure 6 – Mezzo VCA Schematic Implementation Example

Figure 7 contains a rendering with the WAGO Configurator of the Mezzo VCA schematic shown in Figure 6.

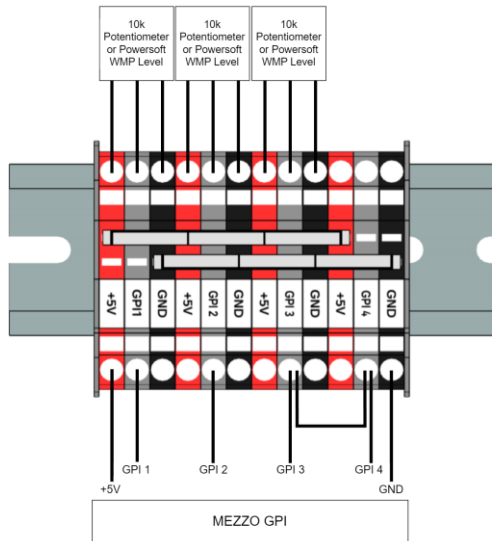

Figure 7 – Mezzo VCA Physical Implementation Example

1.2 Generic Integration With Emergency-Mute Contact Closures

The integration of Mezzo with Emergency-Mute triggers outside of a DMD system is achieved by utilizing the VCA channel level controls. By holding them to +5V the channel output level is set to negative infinity as shown in Figure 8.



Figure 8 – +5V applied to GPI1 has muted channel 1, nothing applied to GPI2 means that channel 2 gain is unaffected.

This can be achieved with Normally Open connections as shown in Figure 9 and implemented in an installation as detailed in Figure 10. A Normally Closed configuration can be supported using a separate pull-up resistor as shown in Figure 11, this can be neatly implemented as shown in Figure 12.

NOTE: Where multiple connections are required to a single pin on the amplifier it is recommended that the integrator should run these connections through terminal blocks and not attempt to make multiple connections in the phoenix connector on the back of the amplifier as this can be prone to faulty connections, loose strands, and is difficult to troubleshoot.

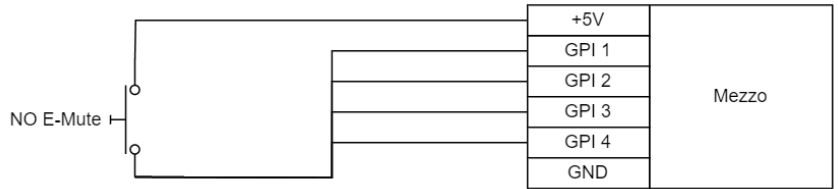

Figure 9 – Mezzo Normally Open E-Mute Circuit

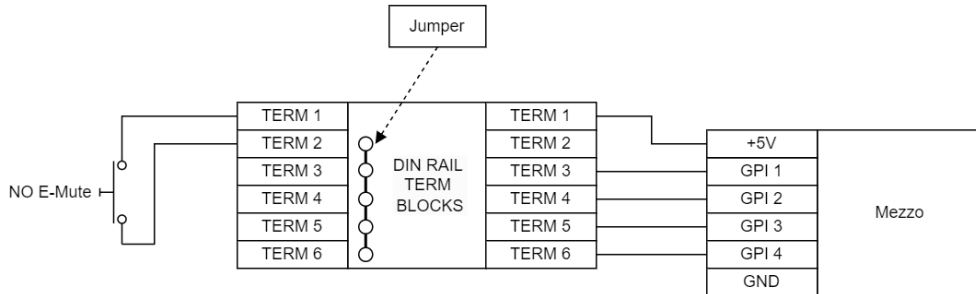

Figure 10 – Mezzo Normally Open E-Mute Implementation Example

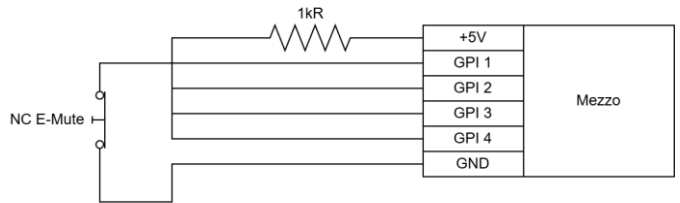

Figure 11 – Mezzo Normally Closed E-Mute Circuit

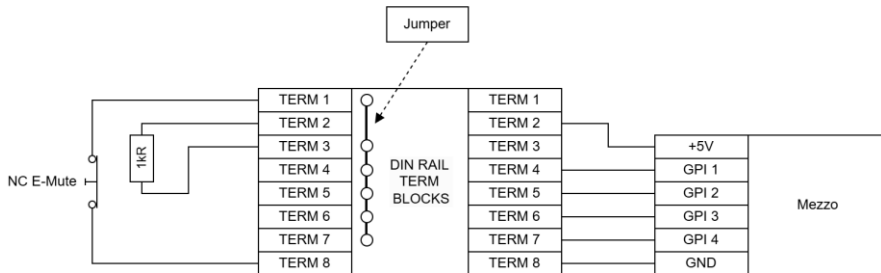

Figure 12 – Mezzo Normally Closed E-Mute Implementation Example

2 CANALI



Figure 13 – Canali GPIO Section

2.1 Overview

The Canali GPIO section features the most fixed-function connections in the amplifier range with dedicated VCA, Remote On/Off, and Alarm sections.

2.1.1 Allowable Voltage Ranges

The Canali Level controls are designed to operate using the supply either side of them, not an external supply, this is 0-5VDC.

The remote on/off GPI is designed to operate within 0-24VDC.

The alarm contact closures are rated for up to 48V.

2.1.2 Alarm

A pair of output relays per channel are available for alarm monitoring. Each channel has a normally closed and a normally open connection as shown in Figure 14. When the amplifier is under normal operation the NO contact is closed and the NC contact is open.

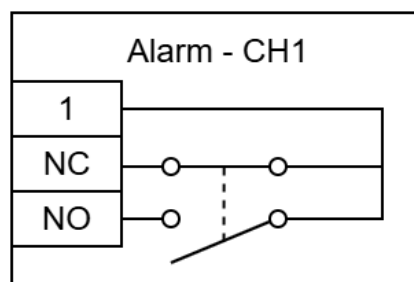

Figure 14 – Canali alarm output schematic (in an alarm state)

The alarm output is triggered by any potentially dangerous faults such as:

- No AC Mains
- Over temperature
- Amplifier is in standby
- Loss of Pilot Tone

- Output monitoring fault
- Channel Faults

2.1.3 VCA Control

The left-hand side features four potentiometer level connections, they provide VCA control of the output level of each channel. A dip-switch is available to enable input 1 to control all four channels. This is especially useful in emergency-mute application as detailed in section 2.2. In the application example shown in Figure 16, the first two potentiometers control channels 1 and 2 respectively, but the third potentiometer is linked to both channel 3 and channel 4 and so will control the output level of both channels.

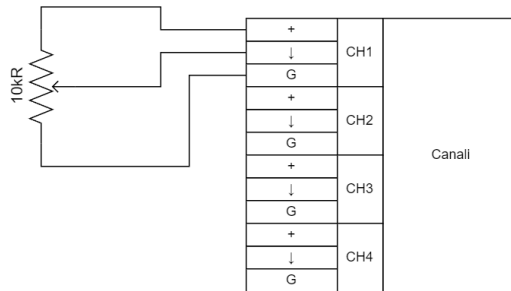

Figure 15 – Canali VCA Circuit

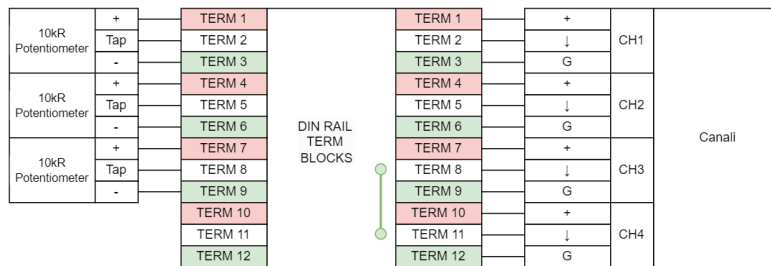

Figure 16 – Canali VCA Application Example

2.1.4 Remote On/Off (Standby)

Applying $\geq 5VDC$ to the Remote On pin will cause the amplifier to turn on. Removing this Voltage will cause the amplifier to return to the state that was previously set by A+ or the webapp.

Applying $\geq 5VDC$ to the Remote Off pin will cause the amplifier to enter standby mode. Removing this Voltage will cause the amplifier to return to the state that it was previously set by A+ or the webapp.

Applying $\geq 5VDC$ to the Remote On will override any setting of the Remote Off pin. The remote on must be $< 5VDC$ for the Remote Off pin to function.

2.2 Generic Integration With Emergency-Mute Contact Closures

The integration of Canali with Emergency-Mute triggers outside of a DMD system can be achieved either with the VCA connections or utilising the remote-off/on connections. Examples of integrating this with Normally Closed E-MUTE relays through both methods is shown in sections 2.2.2 and 2.2.1.

NOTE: Where multiple connections are required to a single pin on the amplifier it is recommended that the integrator should run these connections through terminal blocks and not attempt to make multiple connections in the phoenix connector on the back of the amplifier as this can be prone to faulty connections, loose strands, and is difficult to troubleshoot.

2.2.1 Utilising Remote On/Off

For a normally closed operation the amplifier should be placed into standby via A+ or the web app. 24VDC \geq 5VDC should be applied to the Remote On connection. Upon removing this DC Voltage, the amplifier will enter standby mode.

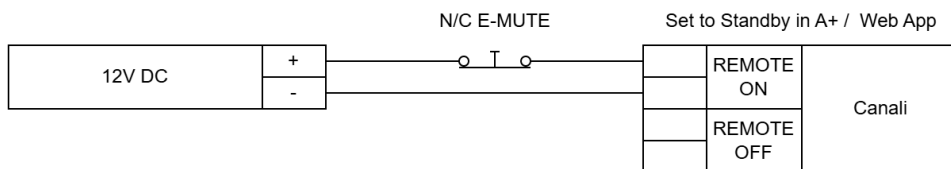

Figure 17 – Canali Normally Closed E-Mute Circuit using Remote ON

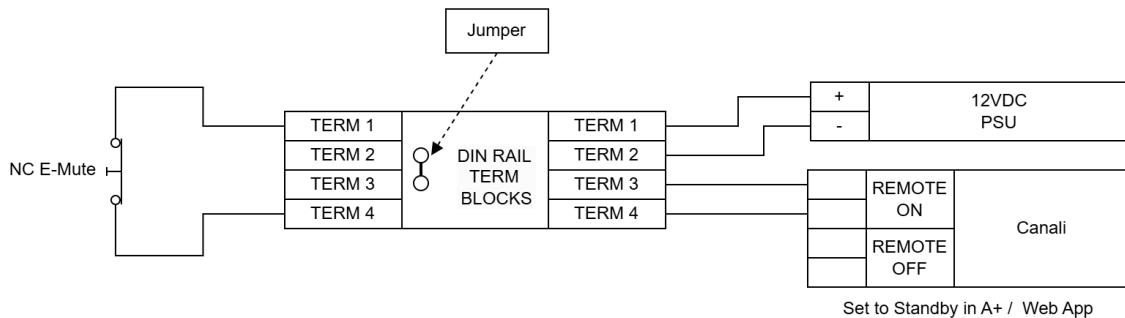

Figure 18 – Canali Normally Closed E-Mute Circuit using Remote ON Application Example

For a normally open operation the amplifier should be taken out of standby by A+ 24VDC \geq 5VDC should be applied to the Remote Off connection. Upon applying the Voltage, the amplifier will enter standby mode.

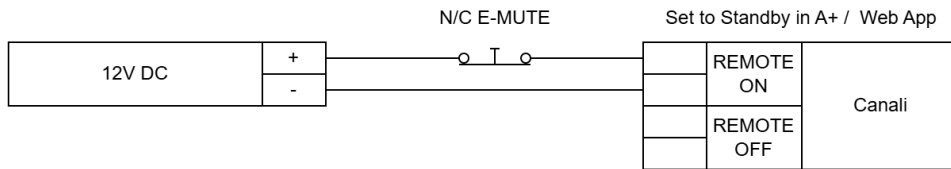

Figure 19 – Canali Normally Open E-Mute Circuit using Remote ON

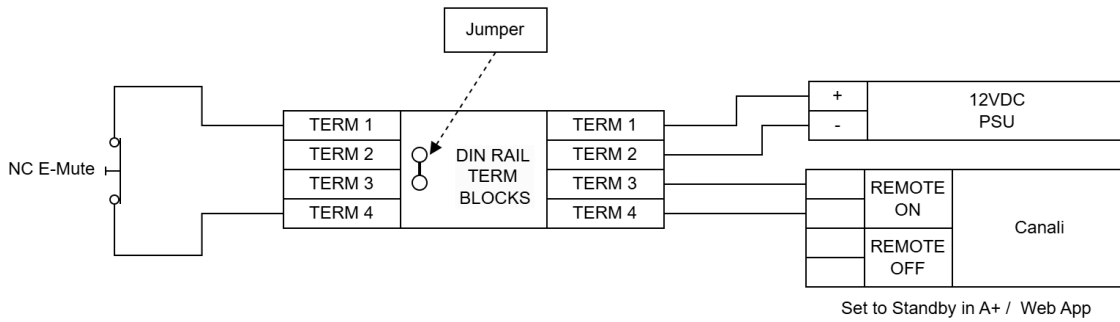

Figure 20 – Canali Normally Open E-Mute Circuit using Remote ON Application Example

2.2.2 Utilising VCA

To utilise the VCA to mute the system, the CH1 MSTR dipswitch should be set so that CH1 is a master VCA for the amplifier.

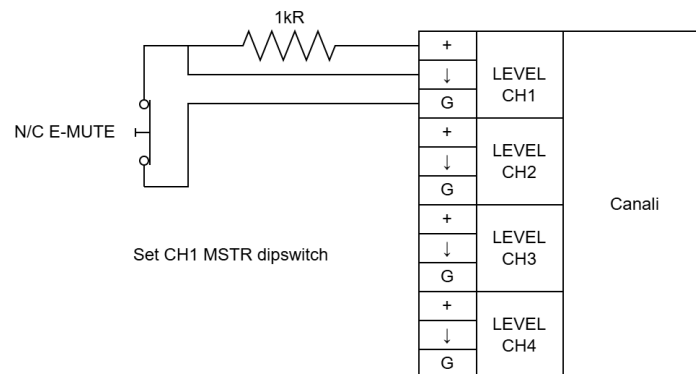

Figure 21 – Canali Normally Closed E-Mute Circuit using VCA

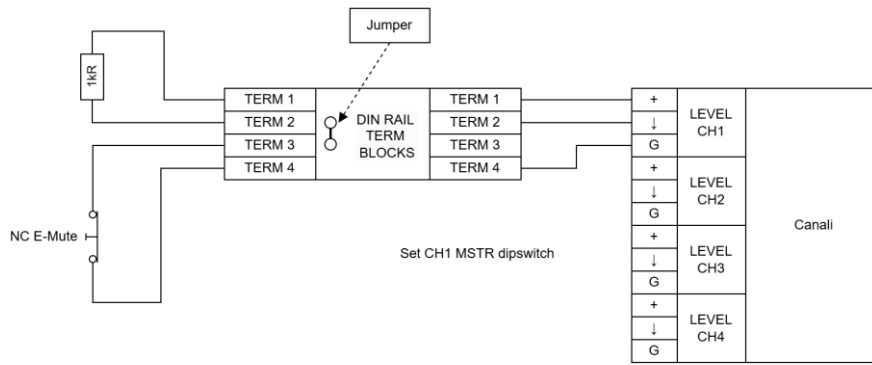

Figure 22 – Canali Normally Closed E-Mute Circuit using VCA Application Example

3 UNICA



Figure 23 – Unica GPIO

3.1 Overview

The Unica GPIO is split into four sections, the left-hand side features a symbol of a switch and is labelled “STS” (for status). Next to this is a stand-by input which puts the amplifier into standby when +5V is present. Next to this is an input labelled “Level”; this acts as a master VCA for the output levels of the amplifier. The right-hand side of the GPIO section is a true General Purpose Input Output (GPIO).

3.1.1 Allowable Voltage Ranges

The Unica GPIO, Level, and Standby Controls are designed for 0-5VDC only.

The contact closure is rated for up to 48V.

3.1.2 Status Contact Closure

The pins labelled “STS” connect to a contact closure that opens in the event of a fault. Under normal operation the relay is closed and will open upon a fault condition such as:

- No AC Mains
- Over temperature
- Amplifier in standby
- Loss of Pilot Tone
- Output monitoring fault
- Channel Faults

3.1.3 Stand-by

The stand-by input puts the amplifier into standby when +5V is present. The default implementation of this is as a normally-open circuit. This means that the amplifier will enter standby mode when 5V is applied to the input pin. This configuration is shown in Figure 24.

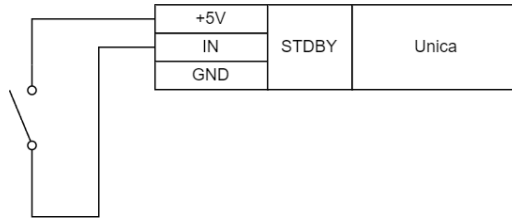

Figure 24 – Unica normally-open standby circuit

A normally-closed configuration can be achieved with the circuit shown in Figure 25, in the state shown in Figure 25 the amplifier would be powered off.

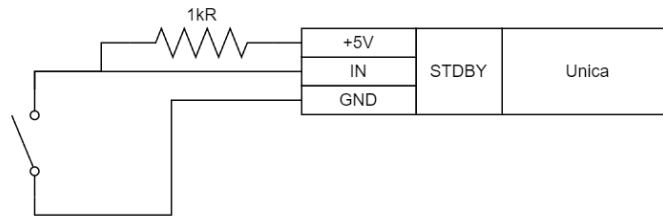

Figure 25 – Unica normally-closed standby circuit

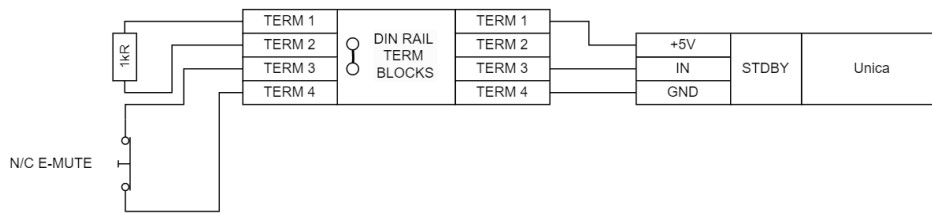

Figure 26 – Unica normally-closed standby implementation example

3.1.4 Master VCA

The input labelled “Level” acts as a master VCA for the output levels of the amplifier. Applying +5V to the level GPI sets the output levels to negative infinity, 0V means that the channel levels are unaffected.

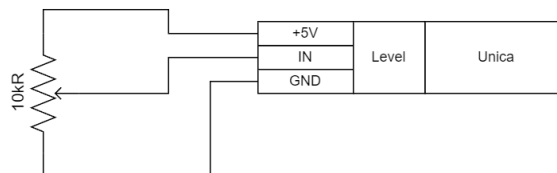

Figure 27 – Unica master VCA Circuit

3.1.5 Configurable GPIO

The GPIO section is a true General Purpose Input Output (GPIO). Each of the 6 pins (labelled X1 through X6) can be assigned one of the following functions:

- No Function (None)
- Ground
- +5V
- VCA Control (for any combination of output channels)
- Mute (for any combination of output channels)
- Device Fault indication
- Input Monitoring Status (for any combination of input channels)
- Load Monitoring Status (for any combination of output channels)

Configuring the GPIO of the Unica is done on an amplifier-by-amplifier basis in the amplifier Options menu as shown in Figure 28 and Figure 29.

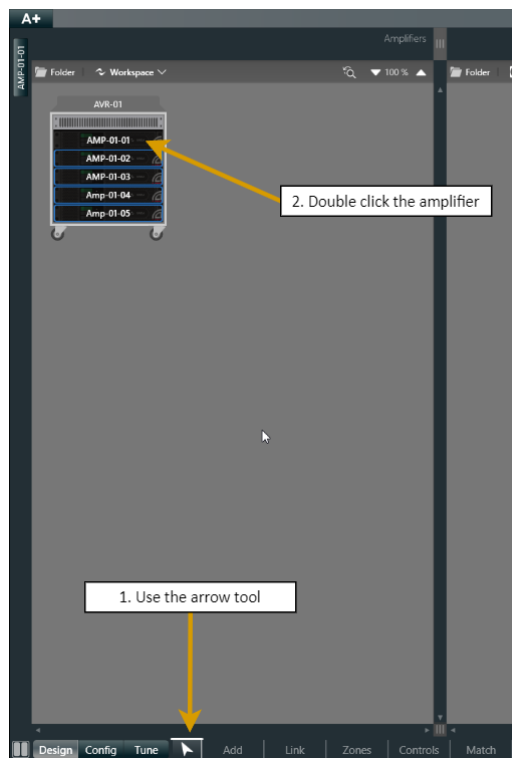

Figure 28 – Configuring Unica GPIO (part 1 – navigating to the amplifier options)

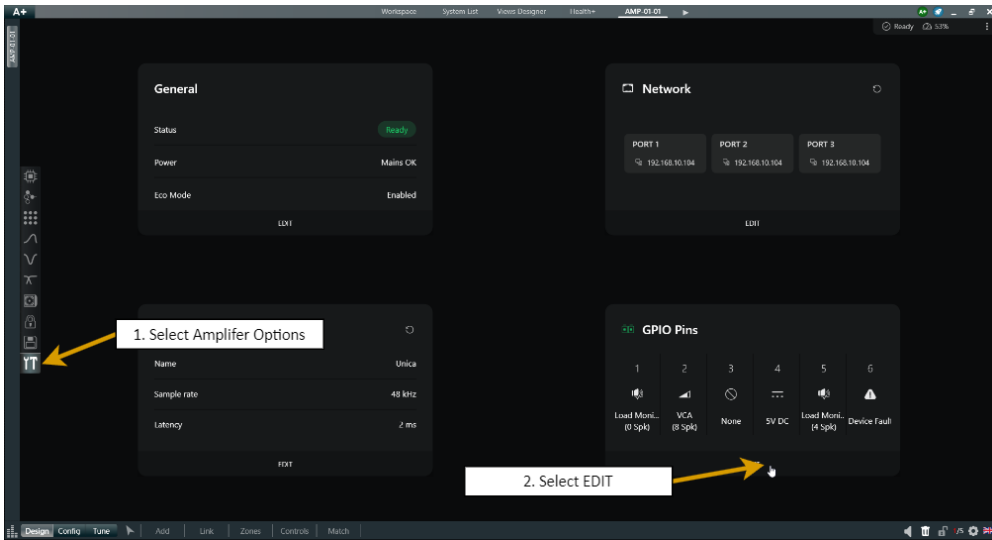

Figure 29 – Configuring Unica GPIO (part 2 – navigating to the GPIO options)

Through the use of these customizable GPIO pins, complex reporting and system control can be achieved.

3.2 Generic Integration with Emergency-Mute Contact Closures

The integration of Unica with Emergency-Mute triggers outside of a DMD system is achieved by utilizing the GPX configured as Input to Mute all outputs.

NOTE: When used with a contact closure, a 120Ω resistor must be included on the +5V line to protect the GPX configured as input.

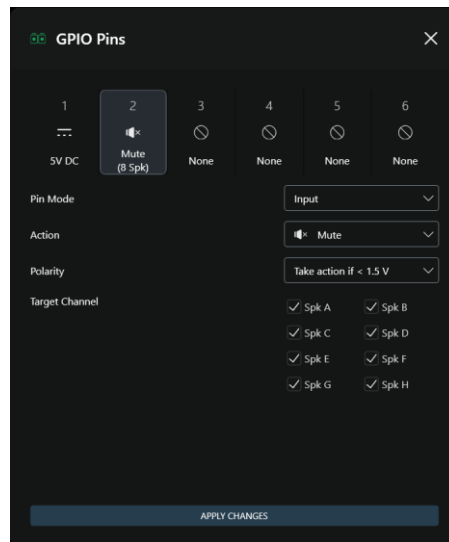

Figure 30 – Unica GPIO configuration for all-mute

The “Polarity” option allows the mute to be triggered with either a normally open or a normally closed input.

NOTE: when testing this, the amplifier will not display a muted status. Instead, the output level will show negative infinity. This is so that the output cannot be un-muted by any API calls from Armonia+ or third-party control systems until the control signal has been removed/restored.

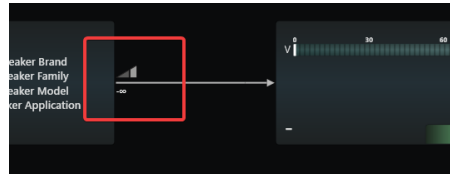

Figure 31 – +5V applied to the Level input has muted the output.

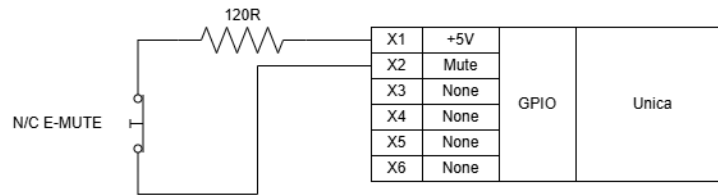

Figure 32 – Unica Normally Closed E-Mute Circuit

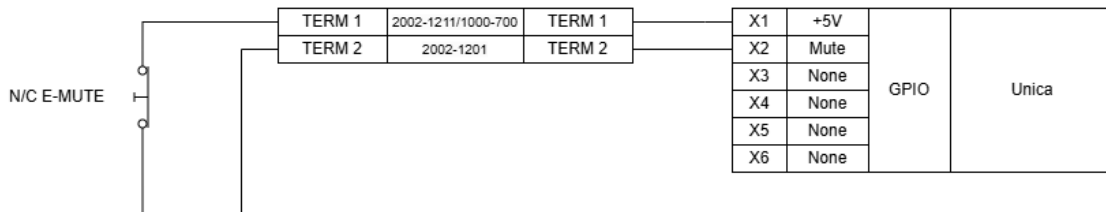

Figure 33 – Unica Normally Closed E-Mute Application Example

4 INTEGRATION WITH DYNAMIC MUSIC DISTRIBUTION

GPI wiring is significantly simplified when used as part of a DMD system. Any GPI of any amplifier in a DMD system can act as:

- a VCA control for any zone within the DMD system (see section 4.1)
- a source selection control from any zone within the DMD system (see section 4.1)
- an emergency source selection to apply to all zones within the DMD system (see section 4.2)
- a standby control for the entire DMD system (see section 4.2)

4.1 Zone Level and Source Select Application Examples

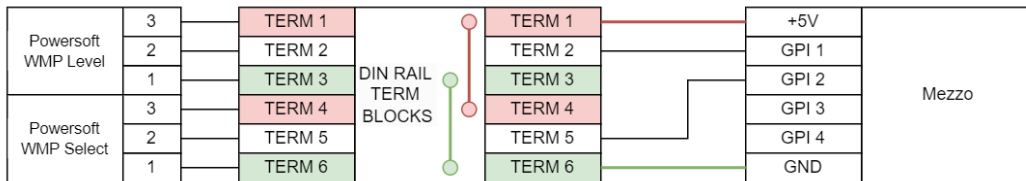

Figure 34 – DMD Zone Level & Source Select with Mezzo GPI

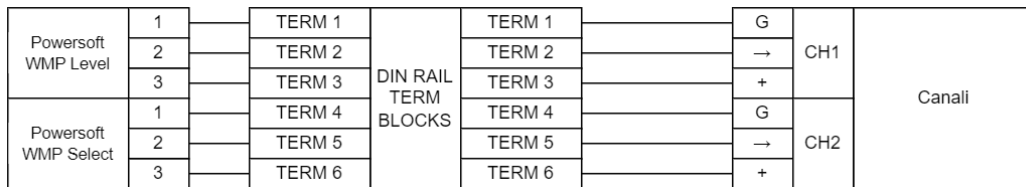

Figure 35 – DMD Zone Level & Source Select with Canali GPI

4.1.1 Implementation in Armonia+

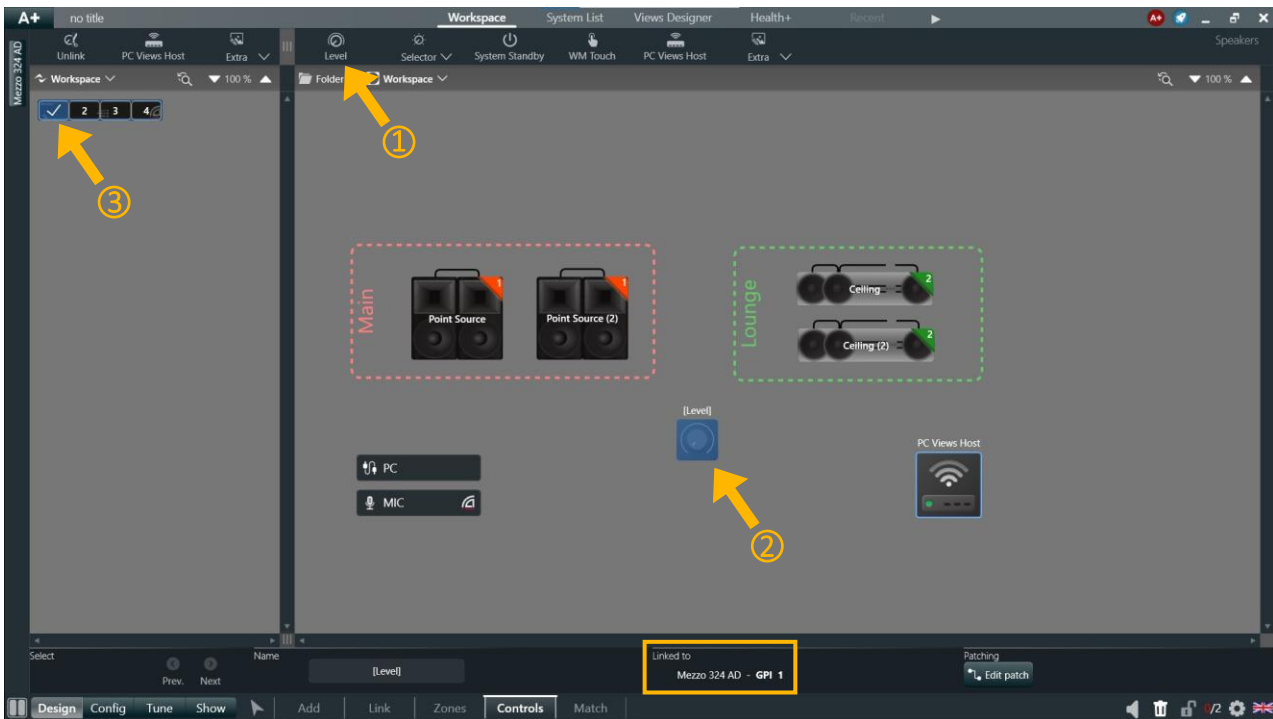

Figure 36 – Linking a WMP Level Controller to a GPI Input of an Amplifier

1. Click on 'Level' icon to add a 'Level' control
2. Click on 'Level' control added to link to a GPI input
3. Click on the desired GPI input to complete the link

4.2 Stand-by and Priority Source Select Application Examples

A DMD system provides the option to put the entire system into stand-by or to switch every zone to a specific input source when a trigger is received. The implementation of this is very simple, as shown in Figure 37.

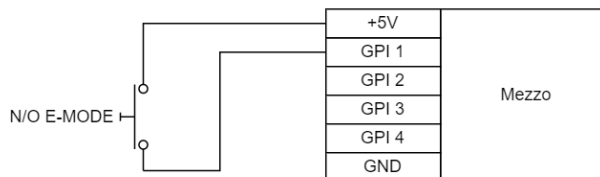

Figure 37 – DMD Normally Open Emergency Mode Trigger Circuit

This can be modified for Normally Closed operation in the same way as was shown for a Mezzo in Section 1.2.

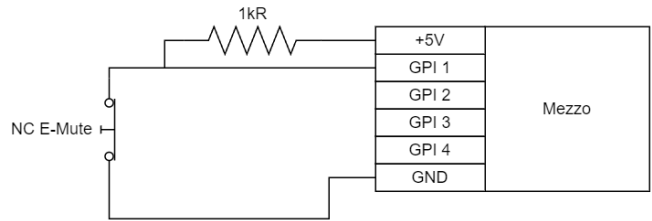

Figure 38 – DMD Normally Closed Emergency Mode Trigger Circuit

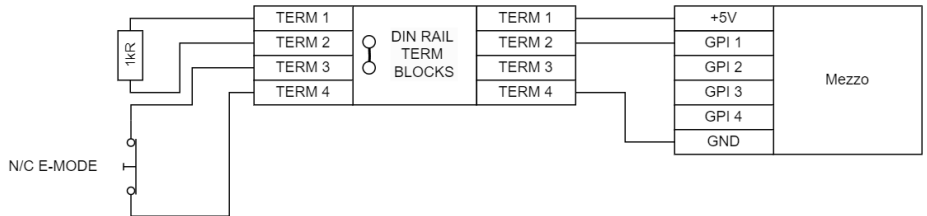

Figure 39 – DMD Normally Closed Emergency Mode Trigger Implementation Example

Linking the system stand-by to a GPI is a great way of implementing a quick “system mute” for integration with emergency systems.

4.2.1 Implementation in Armonia+

System standby can be implemented in Armonia+ in “Design → Controls” mode as shown in Figure 40 and Figure 41.

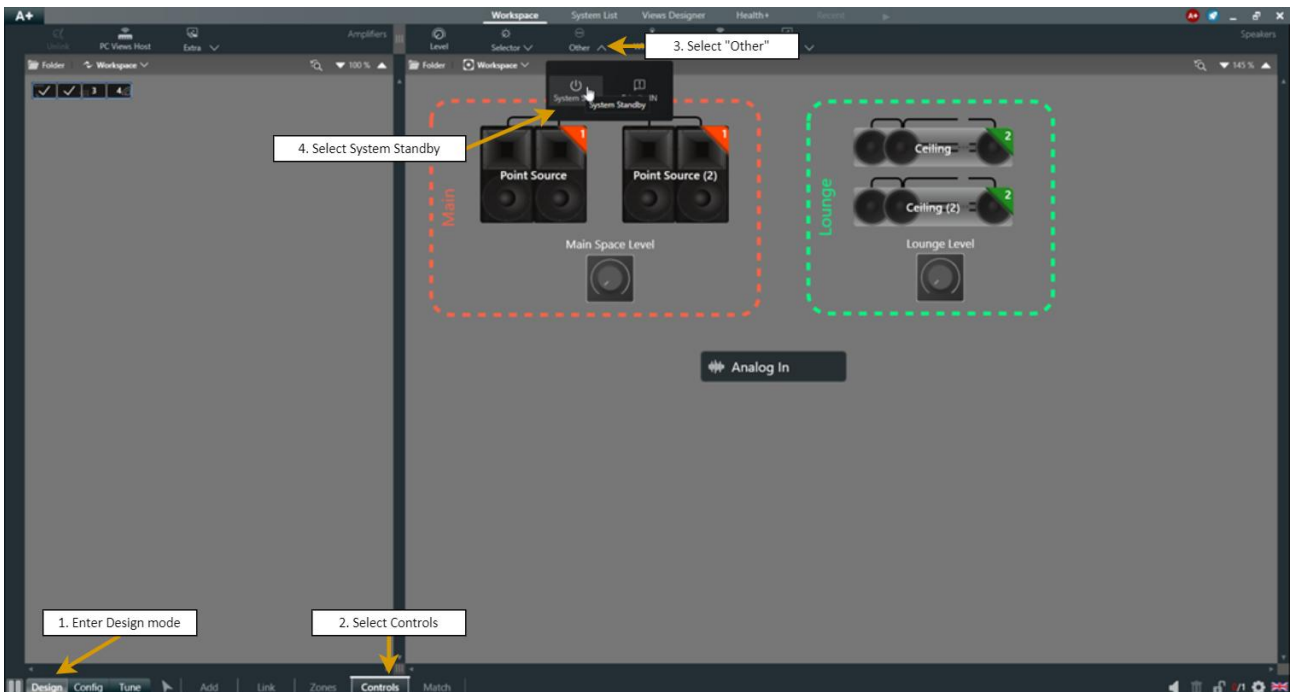

Figure 40 – Adding system standby GPI (part 1 – adding the object)



Figure 41 – Adding system standby GPI (part 2 – linking the object to the GPI)

Note: when this is added to a project, the standby options on the WM Touch, SYS Control App, and Web Views are all disabled when the GPI is active.

The implementation of a priority source selection follows the same process.

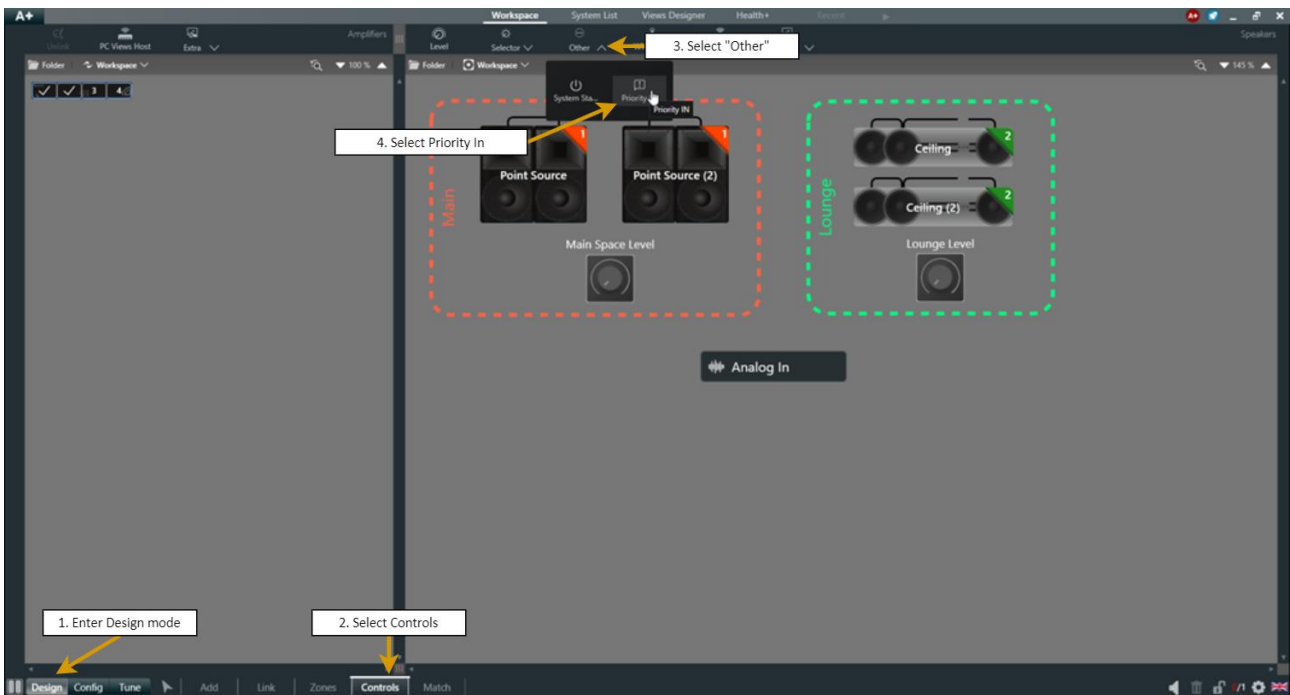

Figure 42 – Adding a GPI triggered priority input (part 1 – adding the object)



Figure 43 – Adding a GPI triggered priority input (part 2 – linking the object to the GPI)

5 APPLICATION EXAMPLES FOR COMMON COMBINATIONS

5.1 Canali + Mezzo N/C Emergency Mute

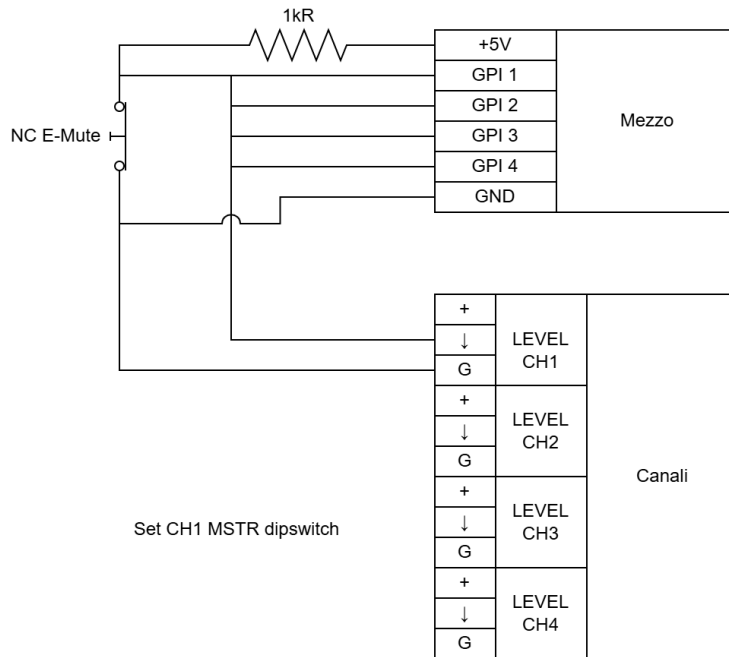

Figure 44 – Mezzo & Canali Normally Closed E-Mute Circuit

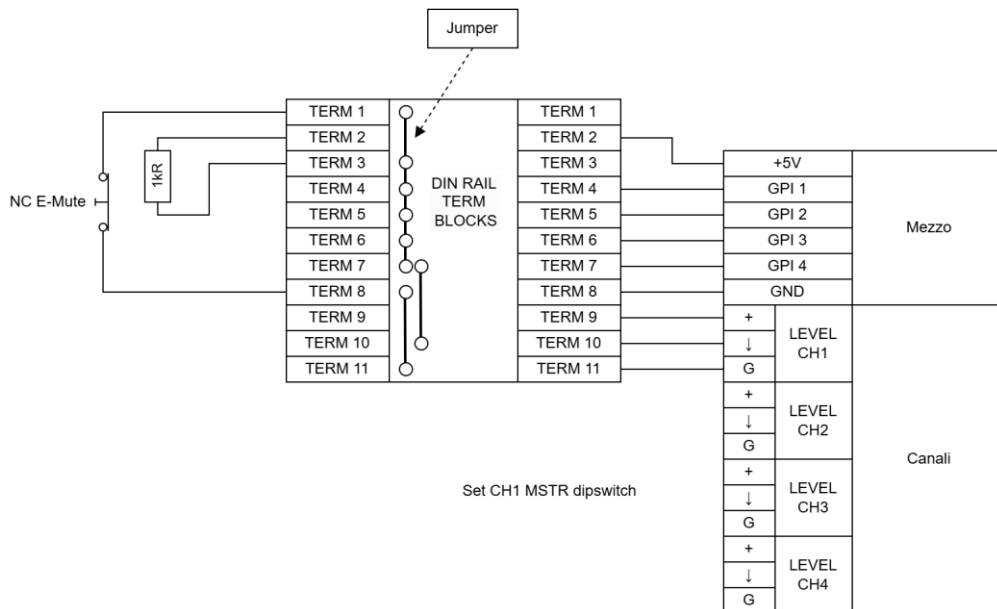

Figure 45 – Mezzo & Canali Normally Closed E-Mute Circuit Application Example

Document Title: GPIO

Reference: DO000345.00 REV.01

Powersoft S.p.A

Via E. Conti, 5- Scandicci (Fi) 50018- Italy

TELEPHONE: +39 055 7350230

Contacts: <https://www.powersoft.com/en/about/contacts/>

www.powersoft.com