

PowerSoft

DIGAM[®]

S SERIES

Digital Audio Amplifier
for Professional Applications

User Manual

Rev: 1.0 – 03/06/2004

Table of Contents

IMPORTANT	2
WARNING NOTICES	2
INTRODUCTION.....	4
INSTALLATION AND OPERATION	5
CONTROLS	6
LED INDICATORS AND CONTROLS	6
REAR PANEL CONTROLS.....	7
PROTECTION.....	7
USER MAINTENANCE	8
WARRANTY AND DISCLAIMERS	8
TECHNICAL ASSISTANCE AND SERVICE.....	9
POWER FACTOR CORRECTION	9
S - SERIES SPECIFICATIONS	10

Important



CAUTION: To reduce the risk of electric shock, do not remove the cover. No user-serviceable parts inside. Refer servicing to qualified service personnel.

SAFEGUARDS: Electrical energy can perform many useful functions. This unit has been engineered and manufactured to assure your personal safety. Improper use can result in potential electrical shock or fire hazards. In order not to defeat the safeguards, observe the following instructions for its installation, use and servicing.

NOTES: This equipment has been tested and found to comply by Competent Body (Directive 89/336/EEC-EMC) pursuant to the product family standard for audio professional use:

EN 55103-1 and EN 55103-2 standard (with the limits for E1 and E2 electromagnetic environment); EN61000-3-2, EN 61000-3-3

This is a Class A product. In a domestic environment this product may cause radio interferences in which case the user may be required to take adequate measures.

This equipment has been tested and found to comply by Notified Body (Directive 73/23/EEC L.V) pursuant to the audio apparatus safety requirements: Standard EN 60065.

Warning Notices

Location

Install the amplifier in a well-ventilated location where it will not be exposed to high temperature or humidity.

Do not install the amplifier in a location that is exposed to direct rays of the sun, or near to hot appliances or radiators. Excessive heat can adversely affect the cabinet and internal components. Installation of the amplifier in a damp or dusty environment may result in malfunction or accident.

Precautions regarding installation

Placing and using the amplifier for long periods on heat-generation sources will affect performances. Avoid placing the amplifier on heat-generating sources. Install this amplifier as far as possible from tuners and TV sets. An amplifier installed in close proximity to such equipment may cause noise or degradation of the picture.

WARNING: To prevent fire or electric shock, do not expose this equipment to rain or moisture.

“Apparatus shall not be exposed to dripping or splashing and no objects filled with liquids, such as vases, shall be placed on the apparatus.”

Safety rules

This device must be powered exclusively by earth connected mains sockets in electrical networks compliant to the IEC 364 or similar rules.

Is absolutely necessary to verify this fundamental requirement of safety and, in case of doubt, require an accurate check by a qualified personal.

The constructor cannot be considered responsible for eventual damages caused to persons, things or data for the missing of accurate earth link.

Before powering this device verify that the amplifier is supplied with the correct voltage rating.

Verify that your mains connection is capable to satisfy the power ratings of the device.

Do not spill water or other liquids into or on the unit.

Do not use this unit if the electrical power cord is frayed or broken.

Do not remove the cover. Removing the cover will expose you to potentially dangerous voltage.

No naked flame sources such like lighted candles should be placed on the amplifier.

Contact the authorized center for ordinary and extraordinary maintenance.

Speaker damage

The DIGAM series amplifiers are among the most powerful professional amplifiers available and are capable of producing much more power than many loudspeakers can handle. It is the user's responsibility to use suitable speakers with the amplifier and to use them in a sensible way that will not cause damage.

Powersoft will not be responsible for damaged speakers. Consult the speaker manufacturer for power-handling recommendations.

Even if you reduce the gain using the amplifier's front panel attenuation controls, it is still possible to reach full output power if the input signal level is high enough.

A single high-power crescendo can damage high-frequency drivers almost instantaneously, while low-frequency drivers can usually withstand very high, continuous power levels for a few seconds before they fail. Reduce power immediately if you hear any speaker "bottoming out" - harsh pops or cracking distortion that indicate that the speaker voice coil or diaphragm is striking the magnet assembly.

Powersoft recommends that you use amplifiers of this power range for more headroom (cleaner sound) rather than for increased volume.

Speaker output shock hazard

A DIGAM amplifier is capable of producing hazardous output voltages. To avoid electrical shock, do not touch any exposed speaker wiring while the amplifier is operating. This manual contains important information on operating your DIGAM amplifier correctly and safety. Please read it carefully before operating your amplifier. If you have any questions, contact your Powersoft dealer.

This manual contains important information on operating your DIGAM amplifier correctly and safety. Please read it carefully before operating your amplifier. If you have any questions, contact your Powersoft dealer.

Introduction

Powersoft is a leading company in the field of high efficiency audio power management. The totally new Powersoft's DIGAM (DIGital AMplifier) technology has changed the way the world looks at professional audio amplification. No other amplifiers come close for applications demanding high power and long term reliability.

Thanks to amazing reductions in heat output along with reductions in weight and the characteristic high output power, DIGAM amplifiers can be used in an unlimited range of applications such as concert touring, opera houses, theatres, churches, cinema, theme parks, television sound stages and industrial applications.

More sound and less weight

Compared to a conventional amplifier, Powersoft DIGAM technology offers very high efficiency and delivers more power to the loudspeakers with much reduced heat dissipation. This greater efficiency enables dimensions, weight and power consumption to be reduced. The output stages of the amplifiers typically run at 95% efficiency, dissipating only 5% of the input energy as heat.

One of the most interesting characteristics is that DIGAM's efficiency is almost independent of output level. Conventional amplifiers achieve their best efficiency only at full rated power output. Since standard music has an average power density of 40% of the maximum level, conventional amplifiers can easily generate 10 times more heat than DIGAM for the same volume of sound.

Superior Sound-Sonic Accuracy

Crystal-clear highs, and a tight, well-defined low end: the most accurate reproduction of an audio signal. Patented design features ensure very high performance in parameters such as distortion, frequency response, slew rate, power bandwidth and dumping factor.

Totally Digital with High Reliability

The DIGAM series is based on PWM technology that has been used for 30 years or more in power supplies and inverters. PWM provides high reliability, small size, low weight and high efficiency. A PWM converter works as a high frequency sampler, converting the variable amplitude (audio) signal into an impulse sequence with average value equal to the audio input.

DIGAM amplifiers use very high sampling frequencies to obtain high performances across the audio band. Powersoft holds several patents on the DIGAM technology.

The Best Amplifier for Your Mains

Powersoft is the first amplifier constructor to use power factor correction. This unique feature ensures that a predominantly resistive load is presented to the mains power supply, minimizing current distortion and voltage/current displacement. This leads to much improved performance of the amplifier at high levels of output and avoids mains-voltage collapses, typical of standard and switching power supplies. Another great advantage of this technology is that its performance is, to a large extent, independent of the mains voltage. The rated output power does not vary with load/line conditions.

The Show Always Goes On

DIGAM Series is completely protected against every possible error in operation and is designed to work under every condition. It gives you maximum power with maximum safety and increases long-term reliability. Anticipating potential problems at the design stage means your show always goes on!

Installation and Operation

Unpacking

Carefully open the shipping carton and check for any noticeable damage. Every Powersoft amplifier is completely tested and inspected before leaving the factory and should arrive in perfect condition. If you find any damage, notify the shipping company immediately. Be sure to save the carton and all packing materials for the carrier's inspection.

Mounting

All DIGAM amplifiers will mount in a standard 19" rack. Four front panel mounting holes are provided. Your DIGAM amplifier uses a front to rear forced-air cooling system to maintain a low, even operating temperature. Drawn by an internal fan, air flow through the slots in the front panel and go over and through components. The DIGAM series amplifiers feature an "intelligent" variable-speed DC fan which is controlled by heat sink temperature sensing circuits: the fan speed will increase only when the temperature of either heat sink requires it, which keeps fan noise to a minimum and helps cut dust accumulation inside. Under extreme thermal load, the fan will force a large volume of air through the heat sinks. If either heat sink gets too hot, its sensing circuit will reduce the output gain. If the amplifier overheats, another sensing circuit shuts down its circuit to cut off power until it cools to a safe temperature.

The exhaust cooling air is forced out through the rear of the chassis, so make sure there is enough space around the sides of the amplifier to allow the air to escape. If it is rack mounted, make sure the exhaust air can flow without resistance. If you are using a racks with closed back, there must be at least one standard rack space of opening in the front of the rack for every four amplifiers. Amplifiers may be stacked directly on top of each other (no space needed between units), starting from the bottom of the rack.

Operating Precautions

Make sure the AC mains voltage is correct and is the same as that printed on the rear of the amplifier. Damage caused by connecting the amplifier to improper AC voltage is not covered by the warranty.

Make sure the power switch is off before making any input or output connections.

It is always a good idea to have the gain controls turned down during power-up to prevent speaker damage if there is a high signal level at the inputs.

Whether you buy them or make them, use good-quality input and speaker cables. Most intermittent problems are caused by faulty cables. Use good-quality connectors and wire, along with good soldering technique, to ensure troublefree reliability.

Connecting Inputs

Input connections are made via the 3-pin XLR-female combo type connectors on the rear side of the amplifier. The inputs are actively balanced, with polarity as shown in figure below. Input connectors can also work with a standard stereo TRS plug.

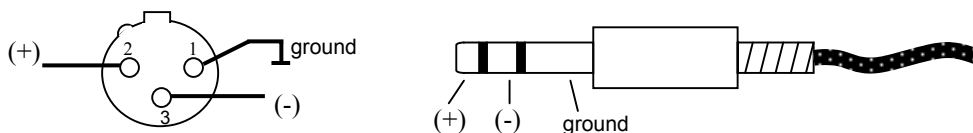

Connecting Outputs

Output connectors are made via neutrik speakon connectors. Look at the wire gauge chart to find a suitable wire gauge to minimize power and damping factor losses in the speaker cables. The outputs can also work *on bridge mode*. For each device the 1+ and 1- pins of speakon connector have to be considered the positive and the negative output of a single channel; the 2+ and 2- pins of speakon connector have to be considered the positive and negative output for bridge mode connection with the adjacent section.

Controls

Input attenuators

The six inputs attenuator controls, located on the front panel adjust gain for their respective amplifier channels in all modes. With the attenuator fully clockwise (minimum attenuation) the amplifier **gain** will be set to **32dB** (40X). The division of the scale is calibrated on **2dB** increasing attenuation, and a step by step detent on potentiometer helps for calibration. The three counterclockwise last positions corresponds to **-∞**, **4** and **14 dB** gain.

In bridge mode the two controls of the bridged couple of channels must be set in the same position.

Led indicators and controls

Led indicators

Your DIGAM amplifier has LED indicators on the front panel. "READY" and "TEMP" leds are common to both channels on each device and the other "SIGNAL" and "PROTECT" leds are present for each channel. Each channel has a 5-segment LED bar for the output signal. Each segment will be lightened every 3dB. The green segments will be lightened during normal working. The yellow LEDs of the bar will be lightened at -3 dB. If the level of the audio signal exceeds the channels output capability, it clips, triggering the red LED.

Front panel controls

The power switch, gain controls and LED indicators are on the front panel.

- 1) Power switch
- 2) Gain
- 3) Protection LED (PROTECT) (one for each channel)
- 4) Signal Present LED (SIGNAL) (one for each channel)
- 5) Over temperature LED (TEMP): one for each power section
- 6) Amplifier ready LED (READY): one for each power section (the led will be on if the amplifier works correctly)
- 7) Output level LED bar
- 8) Air inlets

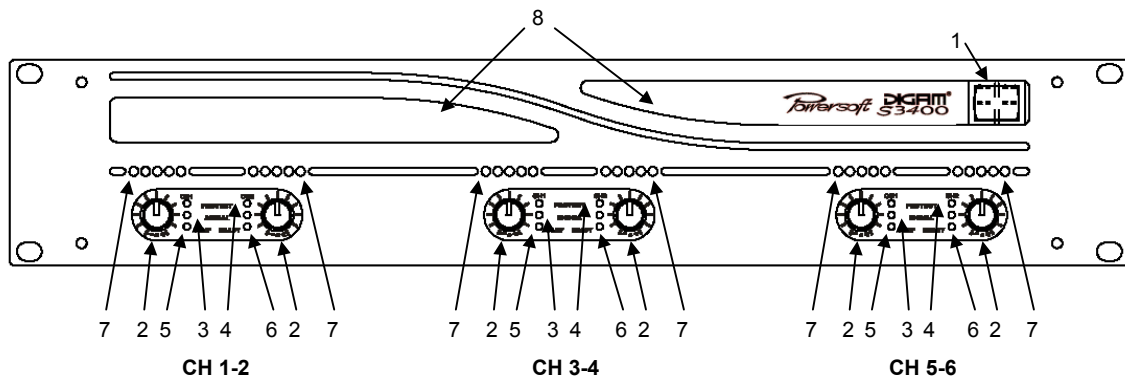

Fig. 1: Front panel

The gain control use a logarithmic scale between $-\infty$ and +32 dB.

Rear panel controls

- 9) Female Neutrik Speakon connectors for audio output for each channel (1+/1- for single channel, 2+/2- for Bridge Mode)
- 10) Female Cannon XLR connectors or stereo Jack (COMBO) for input signal for each channel
- 11) AC main cord
- 12) Cooling fan outlet
- 13) Parallel signal switch

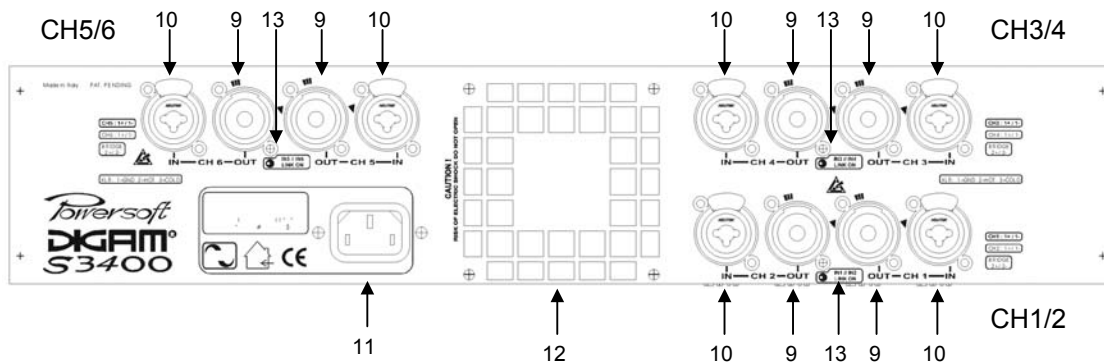

Fig. 2: Rear panel

Protection

Turn-On/Turn-Off Muting

For about four seconds after turn-on, and immediately at turn-off, the amplifier outputs are muted.

Short circuit protection

A short circuit protection system safeguards the amplifier's output devices under short circuits and other stressful loads. It is completely inaudible when inactive. In case of short circuit, the PROTECTION LED will be lightened. An automatic reset circuit restart the amplifier in about two seconds, once there is a permanent short circuit the amplifier doesn't start, otherwise unit will regularly work.

Thermal protection

A DIGAM amplifier uses a continuously variable speed fan to assist cooling (the fan speed changes in response to the amplifier's cooling needs). If the heat sink temperature reaches approximately 60°C, the TEMP LED starts flashing and the output power is gradually reduced. If the temperature is more than 70°C the thermal sensing circuitry will mute each power section channels and the TEMP LED will be light permanently. Once the heatsink has cooled down, the amplifier will automatically unmute and the TEMP LED will be unlighted. It will be possible to reduce the temperature reducing the output power. The TEMP LED flashing indicate only the begin of the thermal control power reduction mode, not the thermal protection intervention. Normally the amplifier can't reach the shut down temperature if there are no problems on the cooling fan or in the air filters or in the installation.

DC fault protection

If DC or excessive subsonic energy appears at a channel output, an instantaneous protection circuit will inhibit the power supply for all channels. Power supply shutdown is used in lieu of speaker relays, thereby improving the damping factor and reliability of the DIGAM amplifiers.

Input/output protection

An ultrasonic network decouples RF from the outputs and keeps the amplifier stable with reactive loads.

User maintenance

Cleaning: Disconnect the amplifier from the AC main source first; use a soft cloth and mild non-abrasive solution to clean the faceplate and chassis.

Dust removal: Especially in a dusty environment, the heat sink may clog with dust after prolonged use, which will interfere with cooling. You may use compressed air to remove the dust; severe cases, though, should be referred to qualified service personnel for a thorough cleaning with the top cover removed.

There are no user-serviceable parts in your DIGAM amplifier. Refer servicing to qualified technical personnel.

In addition to having an in-house service department, Powersoft supports a network of authorized service centers. If your DIGAM amplifier needs repair, contact your Powersoft dealer or distributor, or contact the Powersoft Technical Service department, to obtain the location of the nearest authorized service center.

Warranty and disclaimers

Disclaimer

Powersoft is not liable for any damage to speakers, amplifier, or any other equipment that is caused by negligence or improper installation and/or use of the DIGAM amplifier.

Product warranty

Powersoft guarantees the DIGAM to be free from defective material and/or workmanship for a period of one year from date of sale, and will replace defective parts and repair malfunctioning products under this warranty when the defect occurs under normal installation and use - provided the unit is returned to our factory via prepaid transportation with proof of purchase (sales receipt). This warranty provides that examination of the returned product must disclose, in our judgment, a manufacturing defect. This warranty does not extend to any product that has been subject to misuse, neglect, accident, improper installation, or where the date code has been removed or defaced.

Technical assistance and service

Servicing your unit requires a trained technician capable of performing the type of service you need. There are no user serviceable components inside your unit and the danger of electric shock exists. Additionally, some of the components in your unit are Powersoft specific parts that require Powersoft replacements.

Technical assistance

If you suspect that your amplifier is defective, check your system configuration and amplifier settings to determine the origin of the problem. In many cases, incorrect audio interfacing, poor cabling, or other system level impairments are the cause of problems in audio systems. For technical assistance beyond the information given in this manual, the Powersoft technical Services department may be contacted.

Factory service

In the event that your amplifier does need factory service, you may reach the Powersoft Technical Services department for return instructions. A Return Authorization (RA) number must be obtained from Powersoft Technical Services department. Powersoft may not account for products that are returned without a Return Authorization number.

Product Return Guidelines

1. Pack the product well for protection during shipment.
2. Include a copy of the sales receipt, your name, return address, phone number, and defect description with your return correspondence.
3. Call the Powersoft Technical Authorization Services department for an outside of the packaging.
4. Ship the product prepaid to Powersoft. We recommend United Parcel service (UPS).

*Powersoft S.r.l.
C.A. Technical Service Department
Web: www.powersoft.it
E-mail: support@powersoft.it*

International servicing

For Powersoft products that are purchased outside of the Italy, service must be referred to the distributor or dealer from where the product was purchased. There are numerous service centers in many countries. The service centers in your country may be located by your dealer or distributor.

Power Factor Correction

The DIGAM amplifier has an automatic power factor correction system for a perfect main network interface. The amplifier is a resistive load for the main network, minimizing the reactive power and the harmonic distortion on the current. The system allows performance to be maintained even in circumstances of varying the mains voltage and/or frequency.

S - Series specifications

General

Type	Digital amplifier for professional applications
Power requirements:	115-230Vac 50-60Hz +15/-15%
Power factor $\cos(\varphi)$	More than 0.95 from 200W to full power
Operating temperature	0°C ÷ +45°C
Weight	13,7 kg
External dimensions	Standard rack 19" (W), 2 units (H), 400mm (D)
Consumption average	900 VA

Audio section

Bandwidth (1W, 8Ω)	5 Hz ÷ 30 kHz
Damping factor (8Ω)	100 Hz = 600 10KHz=100
Slew Rate (8Ω)	40v/μs (input filter bypassed)
S/N ratio	More than 105 dB/A (20Hz to 20KHz)
Distortion	THD: Max < 0.5% from 0.1W at full power (typically < 0.1%)
Intermodulation SMPTE	Max < 0.5% from 0.1W at full power (typically < 0.1%)
Intermodulation DIM 100	Max < 0.02% from 0.1W at full power (typically < 0.01%)
Inputs	Balanced to ground, XLR female combo jack 6.3mm
Impedance	10 KΩ each leg, balanced to ground
Gain	32 dB (32, 30, 28, 26, 24, 22, 20, 18, 14, 4, -∞, control knob detent selection)
Outputs	Neutrik4-pole speakon connectors [pins 1+ 1 – (2+/2- bridge)]

Output specifications

RMS Power x Channel (W), EIAJ Test	CH 1-2		CH 3-4-5-6		
	Single	Bridge	Single	Bridge	
1KHz, < 1% THD					
All channels working					
(1KHz, 0.5% THD)	4 Ω	850	N.A.	430	NA
	8 Ω	450	1700	215	860
	16 Ω	230	900	120	460

Functions

Power Factor Correction System (PFC)

Led bar indicator / Over-temperature forecasting / Thermal protection / Gain control / Short-circuit and Over-load output protection / Temperature controlled air-cooling system / Clip limiter and permanent signal compressor

Options

Remote control interface